



# erga

## **ERGA DRAFTING STANDARDS HANDBOOK 2013**

**Prepared By: Nicole Akiki  
Walid Badri**



# TABLE OF CONTENTS

TABLE OF CONTENTS.....	3
<b>I. SHEET NUMBERING .....</b>	<b>7</b>
<b>II. ERGA ARCHITECTURAL LAYERS .....</b>	<b>13</b>
<b>A. STARTING NEW FILE with Erga Architectural Template .....</b>	<b>13</b>
<b>B. ADDING <i>Erga Architectural Layers</i> TO EXISTING DRAWINGS .....</b>	<b>13</b>
<b>C. CREATING New Layers .....</b>	<b>13</b>
<b>D. ERGA AIA Architectural Layers LIST.....</b>	<b>14</b>
<b>III. ERGA TOOL PALETTES .....</b>	<b>21</b>
<b>A. SETTINGS.....</b>	<b>21</b>
<b>B. ANNOTATION SCALE.....</b>	<b>22</b>
<b>C. DYNAMIC BLOCKS.....</b>	<b>24</b>
<b>D. ERGA TOOLS.....</b>	<b>25</b>
1. EG-Architectural Palette .....	25
2. EG-Commands .....	29
3. EG-Tags& Symbols .....	31
4. EG-Hatch Patterns.....	37
<b>E. ERGA ANNOTATIVE TOOLS.....</b>	<b>41</b>
1. ANNOTATIVE OBJECTS .....	41
2. HANDELING DRAWINGS WITH MULTIPLE SCALES .....	41
<b>IV. DRAFTING CONVENTIONS .....</b>	<b>47</b>
<b>A. GRID LINES .....</b>	<b>47</b>
<b>B. PLANS.....</b>	<b>47</b>
<b>C. ELEVATIONS.....</b>	<b>49</b>
<b>D. BUILDING SECTIONS.....</b>	<b>51</b>
<b>E. WALL SECTIONS .....</b>	<b>51</b>
<b>F. ENLARGED FLOOR PLANS.....</b>	<b>52</b>
<b>G. STAIR SECTIONS.....</b>	<b>53</b>
<b>V. DRAFTING CHECK LISTS FOR ARCHITECTURAL DESIGN .....</b>	<b>57</b>
<b>USEFUL INFORMATION FOR ARCHITECTURAL DESIGN .....</b>	<b>57</b>
<b>DRAFTING PERMIT CHECKLIST .....</b>	<b>61</b>
<b>DRAFTING PRELIMINARY CHECKLIST .....</b>	<b>65</b>
<b>DRAFTING CONSTRUCTION CHECKLIST .....</b>	<b>67</b>







# **I. SHEET NUMBERING**



# I. SHEET NUMBERING

Sheet nbr.									
<b>TAC-A - 101B-R01</b>									
Phase	Sector	Building	Discipline	Sub-Disc.	Sheet Type	Sequence Number	Dwg.Part		Revision

## PHASE:

<b>X</b>	Conceptual
<b>R</b>	Preliminary
<b>D</b>	Design Development
<b>P</b>	Permit
<b>T</b>	Tender
<b>C</b>	Construction
<b>B</b>	As Built
<b>H</b>	Habitat

## SECTOR:

“Alphabetical” up to 2 digits/Use “X” for all Sectors  
*(Description to be cancelled if not used)*

## BUILDING:

“Alpha numeric” up to 2 digits/Use “X” for all Buildings.  
*(Description to be cancelled if not used)*  
 (for civil drawings, they are replaced by axis & axis Nbr.)

## DISCIPLINE:

<b>A</b>	Architecture
<b>C</b>	Civil
<b>D</b>	Decoration
<b>E</b>	Electrical
<b>F</b>	Fire Fighting
<b>G</b>	General
<b>L</b>	Landscaping
<b>M</b>	Mechanical
<b>N</b>	Signage
<b>P</b>	Plumbing & Piping
<b>Q</b>	Quantity Surveying
<b>S</b>	Structure Concrete
<b>T</b>	Structural Steel
<b>U</b>	Urbanism

## SUB DISCIPLINE:

### ARCHITECTURE

- No Sub Discipline  
**B** Brochure (Sales Plans)  
**D** Demolition  
**E** Existing  
**F** Fire Zoning  
**G** Green Design (Sustainable)  
**H** Facade Lighting  
**I** Ironmongery  
**L** Landscaping  
**M** Masonry  
**N** Signage  
**Q** Equipment  
**R** Rendering  
**S** Site Work  
**T** Interiors  
**X** External Walls(Fences)

---

### CIVIL

- No Sub Discipline  
**B** Bridges  
**C** Culverts  
**D** Drainage and Storm water  
**F** Fire Network  
**G** Grading  
**I** Irrigation  
**L** Tunnel  
**M** Demolition  
**N** Marine Works  
**R** Roads  
**S** Waste Water Distribution-Sewage  
**T** Transportation  
**U** Utilities  
**W** Water Distribution

---

### ELECTRICAL

- No Sub Discipline  
**A** Automation and Control  
**C** Low Current Distribution  
**D** Decorative Lighting Design  
**E** Grounding & Lightning  
**F** Fire Alarm System  
**G** Diagram  
**I** Intercom  
**L** Lighting  
**M** CATV / SMATV  
**N** IT Network  
**O** Access Control and Intrusion  
**P** Power Distribution  
**R** Greenery Light Design  
**S** Electrical Network  
**T** CCTV  
**U** Public Address  
**V** Audio Visual  
**X** Facade Lighting Design  
**Z** Structure Cabling

---



<b>FIRE FIGHTING</b>	-	No Sub Discipline
	<b>A</b>	Fire Detection & Alarm
	<b>X</b>	Fire Suppression
	---	
<b>LANDSCAPING</b>	-	No Sub Discipline
	<b>D</b>	Drainage
	<b>H</b>	Hardscape
	<b>L</b>	Lighting
	<b>P</b>	Planting
	<b>R</b>	Irrigation
	<b>W</b>	Water Fountains
	---	
<b>MECHANICAL</b>	-	No Sub Discipline
	<b>A</b>	Air Conditioning-Ducting
	<b>G</b>	Gas
	<b>H</b>	Heating
	<b>P</b>	Air Conditioning-Piping
	<b>S</b>	Network
	<b>V</b>	Ventilation
---		
<b>PLUMBING</b>	-	No Sub Discipline
	<b>A</b>	Compressed Air
	<b>D</b>	Drainage
	<b>G</b>	Gas
	<b>I</b>	Rain Water
	<b>M</b>	Medical Gas
	<b>R</b>	Irrigation
	<b>S</b>	Network
	<b>W</b>	Water Supply
	---	
<b>STRUCTURE</b>	-	No Sub Discipline
	<b>D</b>	Demolition
	<b>E</b>	Existing
	<b>F</b>	Concrete Form Work
	<b>H</b>	Excavation and Shoring
	<b>L</b>	Landscaping
	<b>R</b>	Steel Reinforcement
	<b>S</b>	Structural Steel
	...	
<b>URBANISM</b>	-	No Sub Discipline
	<b>G</b>	Guidelines

**SHEET TYPE:**

- 0 General (Symbols Legend, Notes, Etc.)
- 1 Plans
- 2 Elevations
- 3 Sections & Wall Sections
- 4 Large Scale Views (Plans, Elev., Sec., or Wall Sec.)
- 5 Details
- 6 Schedules And Diagrams / Tables
- 7 Floor Finishing / Road Marking
- 8 Reflected Ceiling
- 9 3d Representations (Perspectives, Photos)

**SEQUENCE NUMBER:** 01 TO 99 .

**DRAWING PART:** “Parts of one same level of a building” – Alphabetical

*(Description to be cancelled if not used)*

**REVISION:** (Where applicable)

- R Revision
- A Alternative
- I Issue for Information

+ REVISION NUMBER: 01 TO 99

N.B.: All fields must be blank if not used.

The background of the page is a complex, abstract wireframe structure composed of numerous thin, light blue lines. These lines form a dense, interconnected network that creates a sense of depth and movement, resembling a digital or architectural mesh. The lines are arranged in a way that suggests a three-dimensional space, with some lines appearing to recede into the distance while others are more prominent in the foreground. The overall effect is one of dynamic, geometric complexity.

## **II. ERGA ARCHITECTURAL**





## II. ERGA ARCHITECTURAL LAYERS

### A. STARTING NEW FILE with Erga Architectural Template

- All new files must be started from the Erga Architectural Template "*Erga-Arch.dwt*" located on "[Z:\Dynamic Blocks\ Erga-Arch.dwt](#)".

It's more suitable to set the "*Erga-Arch.dwt*" as the default drawing template.

**N.B:** For other disciplines use the related Erga Template file located on [Z:\Dynamic Blocks](#)

Example: for Structural use [Z:\Dynamic Blocks\Erga-Str.dwt](#)

- To set the "*Erga-Arch.dwt*" as the default drawing template:

- Go to AutoCAD Options :

*Ribbon:* View Tab → Windows Panel (in Acad2012 and earlier) or User Interface Panel (in Acad2013) → press 

or *AutoCAD Classic:* Tools Menu → select or *Command Line:* options (Shortcut "*op*")

- Open the "*Files*" Tab then go to "*Template Settings*" folder.

Browse for the highlighted paths shown in the next figure.

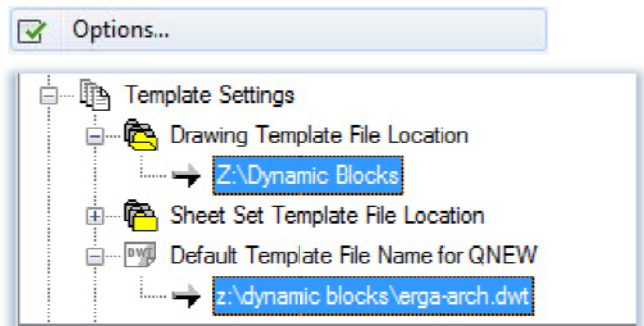
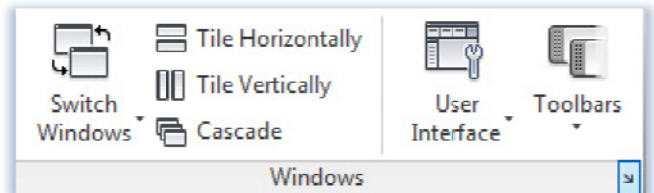

- When starting new file from "*Erga-Arch.dwt*" all architectural layers and all Annotation Scale List will be by default in the drawings.

### B. ADDING Erga Architectural Layers TO EXISTING DRAWINGS

- To add Erga Architectural Layers to an existing drawing go to "*Tool Palettes*" → Erga Tools.

→Open "*EG-Architectural*" palette

→Select "*Insert Architectural Layers*"

→Click in the drawing.

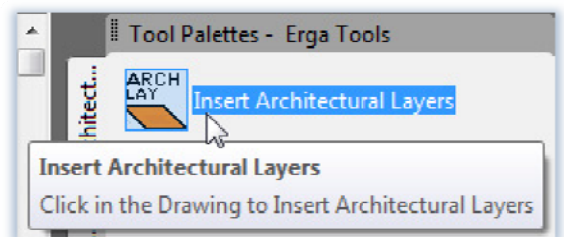

### C. CREATING New Layers

The Layer Name is defined by three data fields: **Discipline - Major Group - Minor Group**

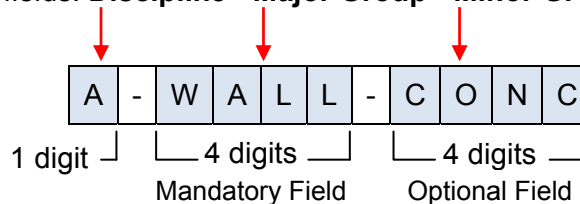

It is mandatory When creating new layers to respect the above format.

The Discipline is the same as in Sheet Numbering (Refer Sheet Numbering page 5)



## D. ERGA AIA Architectural Layers LIST

LAYER NAMES	COLOR	LINETYPE	LINEWEIGHT	DESCRIPTION
A - ANNO - DETL	6	Dashed	0.3	Annotations: detail indicator
A - ANNO - DIMS	142	Continuous	0.09	Annotations: dimensions
A - ANNO - FNSH	32	Continuous	0.18	Annotations: Finishes tags
A - ANNO - IDEN	2	Continuous	0.18	Annotations: Sections & Elevations labels
A - ANNO - KEYN	1	Continuous	0.09	Annotations: Keyplans
A - ANNO - MATC	7	Center	0.4	Annotations: Match lines
A - ANNO - NOTE	6	Continuous	0.3	Annotations: Notes
A - ANNO - NPLT	7	Continuous	0.4	Annotations: Non-plotting graphic information
A - ANNO - SCBR	2	Continuous	0.18	Annotations: Scale bar
A - ANNO - SCHD	6	Continuous	0.3	Annotations: Reports and schedules
A - ANNO - SIGN	4	Continuous	0.18	Annotations: North sign
A - ANNO - TEXT	6	Continuous	0.3	Annotations: Text
A - ANNO - TTLB	2	Continuous	0.18	Annotations: Border and title block
A - ANNO - TXT2	32	Continuous	0.18	Annotations: Text 2mm (regular)
A - ANNO - TXT3	6	Continuous	0.3	Annotations: Text 2mm regular
A - ANNO - TXT4	7	Continuous	0.4	Annotations: Text 4mm subtitles
A - ANNO - TXT6	5	Continuous	0.4	Annotations: Text 6mm main titles
A - ANNO - VPRT	2	Continuous	0.18	Annotations: Viewport borders
A - ANNO	2	Continuous	0.18	Annotations
A - APPL - FIXD	202	Continuous	0.18	Appliances: fixed (ovens / washers / ...)
A - APPL - MOVE	202	Continuous	0.18	Appliances: movable (ovens / washers / ...)
A - AREA - APPR	2	Continuous	0.18	Development: apartment areas
A - AREA - BLCN	9	Continuous	0.13	Legal: balcony areas
A - AREA - COMN	3	Continuous	0.18	Development: common areas
A - AREA - DVID	2	Continuous	0.18	Development: apartment indoor areas
A - AREA - DVOD	9	Continuous	0.13	Development: apartment outdoor areas
A - AREA - IDEN	2	Continuous	0.18	Area: Room dimensions, numbers and tags
A - AREA - INDR	9	Continuous	0.13	Legal: indoor areas
A - AREA - OCCP	9	Continuous	0.13	Area: occupant or employee names
A - AREA - OTDR	32	Continuous	0.18	Legal: outdoor areas
A - AREA - SHFT	9	Continuous	0.13	Legal: shaft areas
A - AREA - USBL	4	Continuous	0.18	Development: usable areas
A - AREA	2	Continuous	0.18	Area
A - CLNG - ACCS	7	Dashed	0.4	Ceiling: access
A - CLNG - ALUM	1	Continuous	0.09	Ceiling: aluminum boards false ceiling
A - CLNG - DIFF	4	Continuous	0.18	Ceiling: diffusers
A - CLNG - GRID	7	Continuous	0.4	Ceiling: false ceiling grid
A - CLNG - GYPS	4	Continuous	0.18	Ceiling: gypsum boards false ceiling
A - CLNG - OPEN	7	Dashed	0.4	Ceiling: openings
A - CLNG - SUSP	7	Dashed	0.4	Ceiling: suspended elements
A - CLNG - TEES	1	Continuous	0.09	Ceiling: main tees
A - CLNG	7	Continuous	0.4	Ceiling: suspended elements
A - COLS - CFRM	7	Continuous	0.4	Columns: concrete form

A - COLS - CONC	5	Continuous	0.4	Columns: concrete
A - COLS - EXTG	6	Continuous	0.3	Columns: Existing
A - COLS - STEL	4	Continuous	0.18	Columns: steel
A - COLS - STON	6	Continuous	0.3	Columns: stone
A - COLS - WOOD	2	Continuous	0.18	Columns: wood
A - COLS	5	Continuous	0.4	Columns
A - CONV - ESTR	8	Continuous	0.09	Conveying systems: escalator
A - CONV - EVTR	2	Continuous	0.18	Conveying systems: elevators, lifts & escalators
A - CONV - IDEN	32	Continuous	0.18	Conveying systems: tags
A - CONV - TRVL	2	Continuous	0.18	Conveying systems: travelator
A - CONV	2	Continuous	0.18	Conveying systems
A - DOOR - IDEN	32	Continuous	0.18	Doors: tags
A - DOOR	134	Continuous	0.18	Doors
A - EQPM - ACCS	202	Continuous	0.18	Equipment: access
A - EQPM - FIXD	202	Continuous	0.18	Equipment: fixed
A - EQPM - IDEN	32	Continuous	0.18	Equipment: tags
A - EQPM - MOVE	202	Continuous	0.18	Equipment: movable
A - EQPM - NICN	202	Continuous	0.18	Equipment: not in contract
A - EQPM - OVHD	202	Dashed	0.18	Equipment: overhead
A - EQPM	202	Continuous	0.18	Equipment
A - FLOR - CASE	244	Continuous	0.09	Floor: casework (kitchens, bathrooms)
A - FLOR - CFRM	1	Continuous	0.09	Floor: concrete form
A - FLOR - DIMS	142	Continuous	0.09	Floor: dimensions
A - FLOR - EXPJ	9	Continuous	0.13	Floor: expansion joint
A - FLOR - EXTG	2	Continuous	0.18	Floor: existing
A - FLOR - FLDR	142	Continuous	0.09	Floor: floor drains
A - FLOR - HIDN	9	Hidden	0.13	Floor: hidden lines in plans
A - FLOR - HRAL	4	Continuous	0.18	Floor: handrails for balconies & fences
A - FLOR - IDEN	4	Continuous	0.18	Floor: Tags for floor levels
A - FLOR - LEVL	4	Continuous	0.18	Floor: level changes, ramps, pits, depressions
A - FLOR - LIN0	1	Continuous	0.09	Floor: projection line
A - FLOR - LIN1	9	Continuous	0.13	Floor: projection line
A - FLOR - LIN2	4	Continuous	0.18	Floor: projection line
A - FLOR - LIN3	6	Continuous	0.3	Floor: projection line
A - FLOR - LIN4	7	Continuous	0.4	Floor: projection line
A - FLOR - OTLN	244	Continuous	0.09	Floor: Outlines
A - FLOR - OVHD	3	Dashed	0.18	Floor: overhead (objects above, Drop beams projection, ...)
A - FLOR - RAIS	6	Continuous	0.3	Floor: raised
A - FLOR - SCRCD	1	Continuous	0.09	Floor: screed
A - FLOR - SHFT	1	Continuous	0.09	Floor: shafts
A - FLOR - SIGN	2	Continuous	0.18	Floor: miscellaneous symbols, signs, ..
A - FLOR - SLAB	7	Continuous	0.4	Floor: slab in wall sections
A - FLOR - SPCL	1	Continuous	0.09	Floor: specialties (toilet room accessories, display cases)
A - FLOR - SYMB	2	Continuous	0.18	Floor: miscellaneous symbols

A - FLOR - TIL1	4	Continuous	0.18	Floor: tiles in section
A - FLOR - TILE	8	Continuous	0.09	Floor: tiles in plan
A - FLOR - TPTN	4	Continuous	0.18	Floor: toilet partitions
A - FLOR - WDWK	134	Continuous	0.18	Floor: architectural woodwork
A - FLOR - WPRF	6	Hidden	0.3	Floor: Waterproof
A - FLOR	244	Continuous	0.09	Floor
A - FURN - CLST	244	Continuous	0.09	Furnishings: closets
A - FURN - FILE	9	Continuous	0.13	Furnishings: file cabinets
A - FURN - FIXD	9	Continuous	0.13	Furnishings: fixed in place
A - FURN - FIXT	114	Continuous	0.09	Furnishings: kitchen, bath and wc fixtures
A - FURN - FREE	9	Continuous	0.13	Furnishings: freestanding
A - FURN - IDEN	2	Continuous	0.18	Furnishing: tags for (closets, furnishing, ...)
A - FURN - PLNT	1	Continuous	0.09	Furnishings: plants
A - FURN - PNLS	9	Continuous	0.13	Furnishings: system panels
A - FURN - SEAT	9	Continuous	0.13	Furnishings: seating
A - FURN - STOR	9	Continuous	0.13	Furnishings: system storage components
A - FURN - WKSF	9	Continuous	0.13	Furnishings: system work surface components
A - FURN	9	Continuous	0.13	Furnishings
A - GLAZ - ASSM	2	Continuous	0.18	Glazing: assemblies
A - GLAZ - CURT	2	Continuous	0.18	Glazing: curtain wall
A - GLAZ - FRAM	134	Continuous	0.18	Glazing: frames in details
A - GLAZ - FULL	11	Continuous	0.18	Glazing: full-height
A - GLAZ - IDEN	32	Continuous	0.18	Glazing: tags
A - GLAZ - PRHT	134	Continuous	0.18	Glazing: partial-height
A - GLAZ - SHTR	134	Continuous	0.18	Glazing: shutter
A - GLAZ - SILL	2	Continuous	0.18	Glazing: sills
A - GLAZ - UNIT	2	Continuous	0.18	Glazing: curtain wall units
A - GLAZ	134	Continuous	0.18	Glazing
A - GRID - DIMS	142	Continuous	0.09	Annotations: Axis dimensions
A - GRID - IDEN	1	Continuous	0.09	Axis: labels
A - GRID	1	Center	0.09	Floor: preliminary grids, Axis grids
A - LITE - FIXT	2	Continuous	0.18	Lighting fixtures
A - PATT - ALUM	8	Continuous	0.09	Patterns: aluminum
A - PATT - BLWO	8	Continuous	0.09	Patterns: block work
A - PATT - BRCK	8	Continuous	0.09	Patterns: roof bricks
A - PATT - BROD	8	Continuous	0.09	Patterns: backing rod
A - PATT - BRST	8	Continuous	0.09	Patterns: brick stone
A - PATT - CFRM	8	Continuous	0.09	Patterns: concrete form
A - PATT - CONC	8	Continuous	0.09	Patterns: concrete
A - PATT - EPLS	8	Continuous	0.09	Patterns: external plaster
A - PATT - EARTH	8	Continuous	0.09	Patterns: earth & soil
A - PATT - FBRC	8	Continuous	0.09	Patterns: fabric
A - PATT - GREN	8	Continuous	0.09	Patterns: green, grass
A - PATT - GRVL	8	Continuous	0.09	Patterns: gravel
A - PATT - GYPS	8	Continuous	0.09	Patterns: gypsum board
A - PATT - METL	8	Continuous	0.09	Patterns: metal

A - PATT - MMBR	8	Continuous	0.09	Patterns: membrane
A - PATT - MRTR	8	Continuous	0.09	Patterns: mortar
A - PATT - PLST	8	Continuous	0.09	Patterns: plaster
A - PATT - RTWL	8	Continuous	0.09	Patterns: retaining wall fill
A - PATT - SAND	8	Continuous	0.09	Patterns: sand
A - PATT - SCRD	8	Continuous	0.09	Patterns: screed
A - PATT - SEAL	8	Continuous	0.09	Patterns: sealant
A - PATT - SH00	255	Continuous	0.2	Patterns: shade 100% black
A - PATT - SH20	254	Continuous	0.2	Patterns: shade 20% black
A - PATT - SH36	253	Continuous	0.2	Patterns: shade 36% black
A - PATT - SH52	252	Continuous	0.2	Patterns: shade 52% black
A - PATT - SH68	251	Continuous	0.2	Patterns: shade 68% black
A - PATT - SH84	250	Continuous	0.2	Patterns: shade 84% black
A - PATT - STEL	8	Continuous	0.09	Patterns: steel
A - PATT - STMP	8	Continuous	0.09	Patterns: Stamped screed, concrete, ...
A - PATT - STON	8	Continuous	0.09	Patterns: stone
A - PATT - TILE	8	Continuous	0.09	Patterns: tiles
A - PATT - WOOD	8	Continuous	0.09	Patterns: wood
A - PATT	8	Continuous	0.09	Patterns: plans, elevations, sites ...
A - PKNG - CARS	1	Continuous	0.09	Parking: vehicles, cars, trucks, airplanes...
A - PKNG - IDEN	1	Continuous	0.18	Parking: tags
A - PKNG - PNTS	253	Continuous	0.2	Parking: (symbols, paints)
A - PROP - LINE	8	Continuous	0.09	Properties: land limits
A - PROP - SBCK	8	Dashed	0.09	Properties: setback limits
A - PROP	8	Continuous	0.09	Properties
A - REFR - IMGS	1	Continuous	0.09	External references: images
A - REFR - XREF	1	Continuous	0.09	External references: plans
A - REFR	1	Continuous	0.09	External references
A - ROAD - CNTR	1	Center	0.09	Road: centerlines
A - ROAD - CURB	8	Continuous	0.09	Road: limits
A - ROAD	8	Continuous	0.09	Road
A - ROOF - BRCK	2	Continuous	0.18	Roof: bricks (in sections)
A - ROOF - INSL	1	Continuous	0.09	Roof: insulation
A - ROOF - LIN0	1	Continuous	0.09	Roof: projection line
A - ROOF - LIN1	9	Continuous	0.13	Roof: projection line
A - ROOF - LIN2	4	Continuous	0.18	Roof: projection line
A - ROOF - LIN3	6	Continuous	0.3	Roof: projection line
A - ROOF - LIN4	7	Continuous	0.4	Roof: projection line
A - ROOF - OTLN	244	Continuous	0.09	Roof: outline
A - ROOF - WPRF	6	Hidden	0.3	Roof: Waterproof
A - ROOF	2	Continuous	0.18	Roof
A - SITE - CTLN	9	Hidden	0.13	Site: Contour lines
A - SITE - FENC	4	Continuous	0.18	Site: fences
A - SITE - FURN	202	Continuous	0.18	Site: furniture
A - SITE - GRND	2	Continuous	0.18	Site: Natural site section line
A - SITE - PLNT	1	Continuous	0.09	Site: outdoor plants, trees, bushes...

A - SITE - SPRT	202	Continuous	0.18	Site: sport fields
A - SITE - SWLK	2	Continuous	0.18	Site: sidewalk
A - SITE - SYMB	1	Continuous	0.09	Site: peoples, animals and miscellaneous outdoor symbols
A - SITE - TILE	8	Continuous	0.09	Site: outdoor tiles
A - SITE	8	Continuous	0.09	Site
A - STRS - HRAL	4	Continuous	0.18	Stairs: handrails for stairs
A - STRS - IDEN	4	Continuous	0.18	Stairs: Tags for treads numbering
A - STRS - RISR	9	Hidden	0.13	Floor: stair risers
A - STRS	2	Continuous	0.18	Stairs: treads, ladders
A - WALL - BLWO	7	Continuous	0.4	Walls: block work
A - WALL - BRCK	7	Continuous	0.4	Walls: roof bricks
A - WALL - CAVI	32	Continuous	0.18	Walls: cavity (double walls)
A - WALL - CNTR	1	Center	0.09	Walls: Centerline
A - WALL - CONC	5	Continuous	0.4	Walls: concrete
A - WALL - DIMS	142	Continuous	0.09	Walls: dimensions
A - WALL - EXPJ	9	Continuous	0.13	Walls: expansion joints
A - WALL - EXTG	5	Continuous	0.4	Walls: existing walls
A - WALL - FIRE	6	Dash dot	0.3	Walls: fire wall
A - WALL - FULL	7	Continuous	0.4	Walls: full-height
A - WALL - GYPS	6	Continuous	0.3	Walls: gypsum board partitions
A - WALL - HEAD	134	Continuous	0.18	Walls: door and window headers
A - WALL - HIDN	9	Hidden	0.13	Walls: Hidden lines
A - WALL - JAMB	134	Continuous	0.18	Walls: door and window jambs
A - WALL - LINO	1	Continuous	0.09	Walls: projection line
A - WALL - LIN1	9	Continuous	0.13	Walls: projection line
A - WALL - LIN2	4	Continuous	0.18	Walls: projection line
A - WALL - LIN3	6	Continuous	0.3	Walls: projection line
A - WALL - LIN4	7	Continuous	0.4	Walls: projection line
A - WALL - LTWT	4	Continuous	0.18	Walls: light weight
A - WALL - MOVE	2	Continuous	0.18	Walls: movable wall partitions
A - WALL - PLST	1	Continuous	0.09	Walls: plaster
A - WALL - PRHT	4	Continuous	0.18	Walls: partial-height
A - WALL - RTWL	7	Continuous	0.4	Walls: retaining wall
A - WALL - SH20	254	Continuous	0.2	Walls: shade 20% black
A - WALL - SH36	253	Continuous	0.2	Walls: shade 36% black
A - WALL - SH52	252	Continuous	0.2	Walls: shade 52% black
A - WALL - SH68	251	Continuous	0.2	Walls: shade 68% black
A - WALL - SH84	250	Continuous	0.2	Walls: shade 84% black
A - WALL - STN1	6	Continuous	0.3	Walls: stone cladding in sections
A - WALL - STON	4	Continuous	0.18	Walls: stone cladding
A - WALL - TIL1	4	Continuous	0.18	Walls: tiles in section
A - WALL - TILE	8	Continuous	0.09	Walls: tiles in plan
A - WALL	7	Continuous	0.4	Walls





### **III. ERGA TOOL PALETTES**



### III. ERGA TOOL PALETTES

#### A. SETTINGS

- open Tool Palettes :
  - Press **[ctrl + 3]**
  - or Ribbon: View Tab → Palettes → Tool Palettes
  - or AutoCAD Classic:
    - Tools Menu → Palettes → Tool Palettes (Figure 1).
    - or Standard Tool Bar →  button.
- Right Click on the Tool Palettes then select **Erga Tools** or **Erga Annotative Tools**
- From the Tool Palettes set the **Drawing Units** and the **Discipline** (Figure2).
- At the Status Bar (the right bottom of the screen) select the proper **Annotation Scale** for the drawing. (Figure3)
 

**N.B:** the scale selected must have **m** (for metric drawings) or **mm** (for millimetric drawings) as a scale suffix. (Refer to Annotation Scale - page 22)

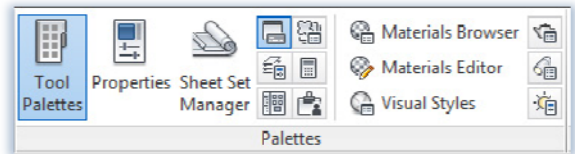

Figure 1

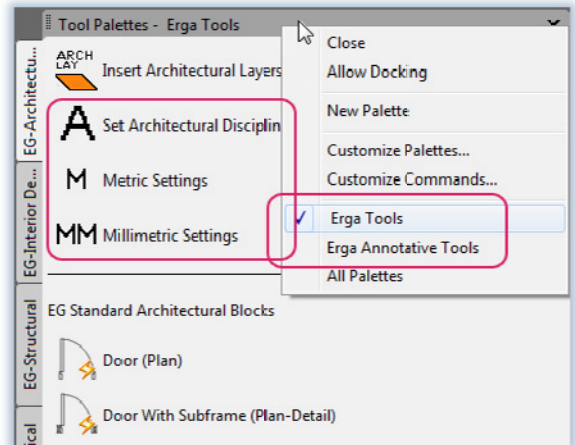

Figure 2

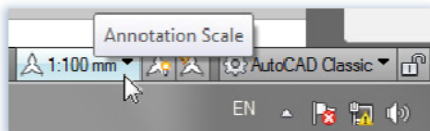

Figure 3

- At the bottom left corner of the Autocad screen , near the coordinates, you must find this note:
 

**Hello "USER" "Discipline" "Drawing Units"** (Figure 4)

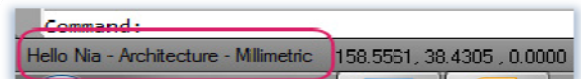

Figure 4

If the mentioned note isn't displayed this could be a sign that the lisp aren't loaded and that the tools won't work properly.

- So make sure that there is no **X** symbol on drive **Z:** and then restart AutoCAD
- If even so the note isn't displayed, inform the IT support: Your station is not properly configured to load ERGA's tools.



**N.B:** The Tool Palettes won't work properly If any of the above steps is skipped.



## B. ANNOTATION SCALE

- By setting the **Annotation Scale** (Refer to Settings n°4 page 21) all annotations inserted from the Palettes will have the proper size at insert.
- If the drawing contains multiple details with different scales you can at any time change the "Annotation Scale" according to the scale of the detail you're working on: the scale of the existing annotations won't change, only the new ones will be affected.

**(N.B: if the annotations are "Annotative" go to section: "Erga Annotative Tools" page 41 in order to learn how to handle "Annotative Objects").**

- As noted before it is mandatory to select the Scale Name's suffix "m" (for metric drawings) or "mm" (for millimetric drawings), because the "**Scale properties**" varies between metric and millimetric drawings. If you don't find in your Annotation scale list any scales with "m" or "mm" suffix, or the scale list is incomplete:
  - Go to Status Bar → Annotation scale → Custom → Reset → select "Metric Scales" or Ribbon: Go to Annotate → Annotation Scaling → Scale List  → Reset → select "Metric Scales"
  - or AutoCAD Classic: Format → Scale List  → Reset → select "Metric Scales"
  - or Command Line: `scaledit` → Reset → select "Metric Scales" the list will be updated
  - If this step doesn't work than contact the IT support they must update your registry file.
  - In AutoCad2010 and earlier versions this step won't work, Annotation scale list must be updated manually by creating *New Custom Annotation scale (see next ...)*
- New Autocad files started with "Erga Template" will have automatically the default scale list. (see STARTING NEW FILE with Erga Architectural Template- page 13)

### - To create a new **Custom Annotation Scale**:

- Go to Task Bar → *Annotation Scale* → *Custom* → *Add* (Figure 5)
- Fill the *Scale name* and the *Scale Properties* (Figure 6)

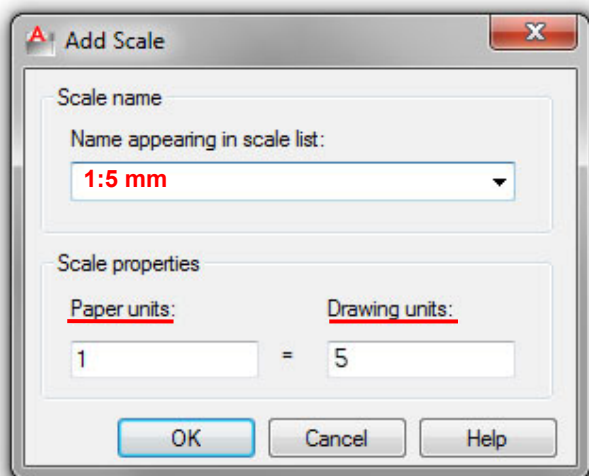

Figure 6

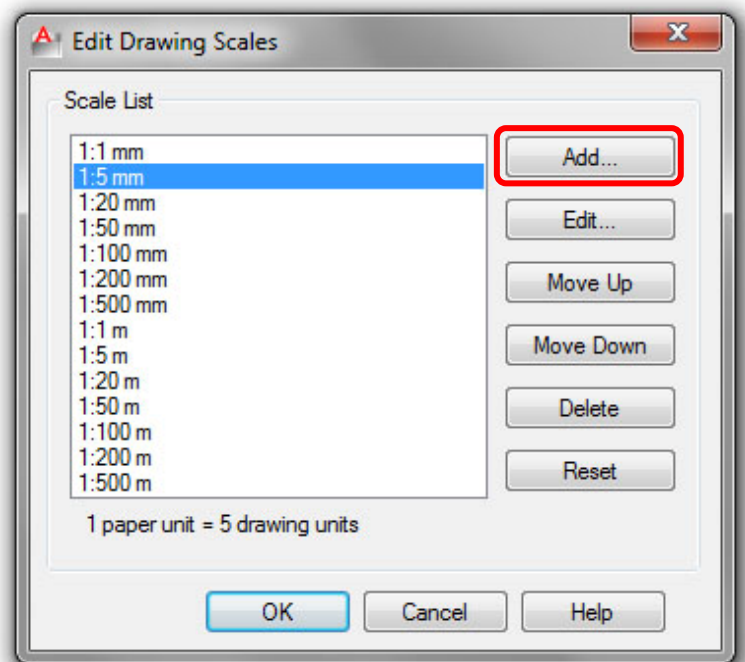

Figure 5

**Scale Properties** Examples:

Scale	Metric Drawing			Millimetric Drawing		
	Paper Units	=	Drawing units	Paper Units	=	Drawing units
1:100	1000	=	100	1	=	100
	or 10	=	1			
1:20	1000	=	20	1	=	20
	or 10	=	2			
1:5	1000	=	5	1	=	5
1:1	1000	=	1	1	=	1

**N.B:** Don't forget to add the "m" or "mm" suffix for the Scale name.



## C. DYNAMIC BLOCKS

Some palettes of the Erga Tool Palettes contains Blocks that are **Dynamic**. These are blocks that after being inserted, can change shape, size, or configuration,... Dynamic block's geometry is manipulate by:

### 1. Custom Grips.

Grip Type		How to Manipulate -Actions
	Standard	Within a plane in any direction to do one of the following: Move, Scale, Stretch, Polar Stretch, Array.
	Linear	Back and forth in a defined direction or along an axis to do one of the following: Move, Scale, Stretch or Array.
	Rotation	Rotate around an axis.
	Flip	Click to flip the dynamic block reference.
	Alignment	Within a plane in any direction; when moved over an object, triggers the block reference to align with the object.
	Lookup	Click to display a list of options.

### Example: Door

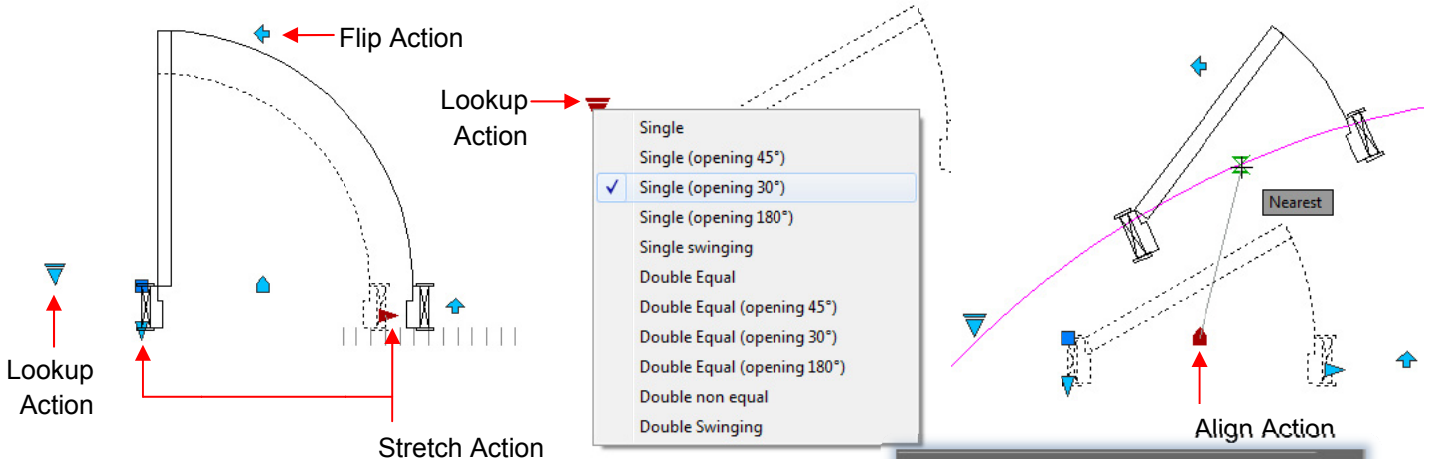

### 2. Properties Palette



Dynamic blocks can also be manipulated from the Properties Palette (ctrl + 1).

- Select the block
- Go to the Properties Palette → "Custom" Section
- Every Grip is associated to a Parameter Name with a value that can be modified in the Properties Palette.

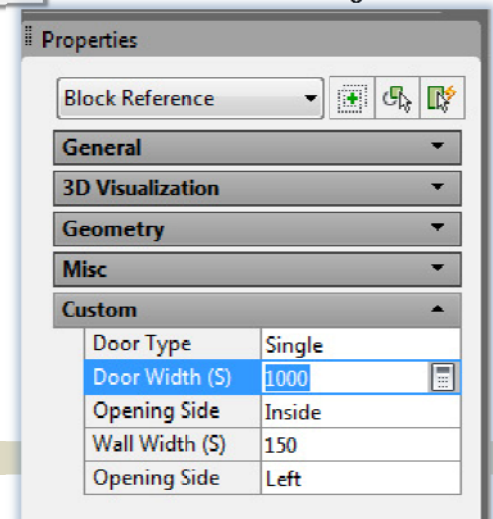











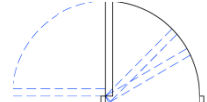

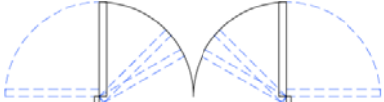

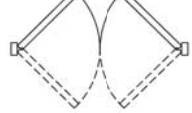

### Example: Door Width

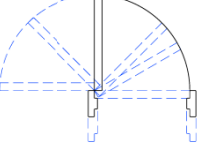
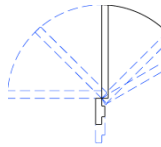
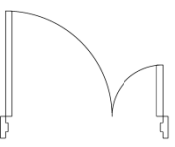
## D. ERGA TOOLS

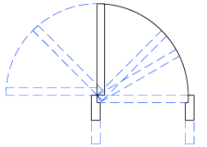
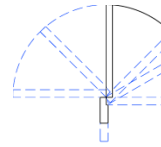
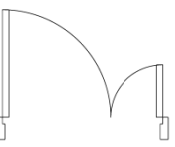

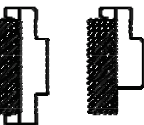
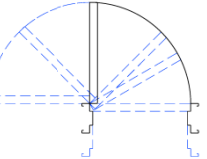
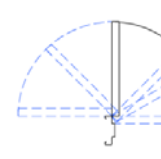
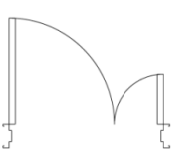
The ERGA TOOLS is a set of 9 palettes:

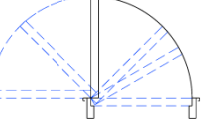
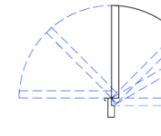
- 5 palettes specific to each Discipline (EG-Architectural, EG-Structural, EG-Mechanical, EG-Electrical, EG-Interior Design) and 4 palettes common to all Disciplines.
- The top part of each palette is related to the *Settings* (Refer to *SETTINGS* page 21).

### 1. EG-Architectural Palette



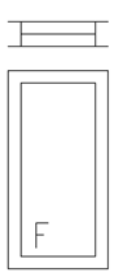

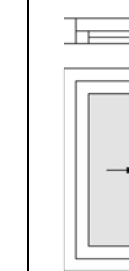
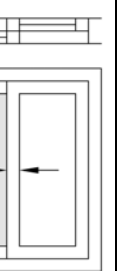
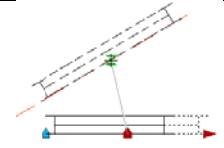
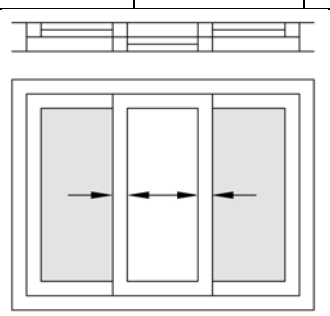
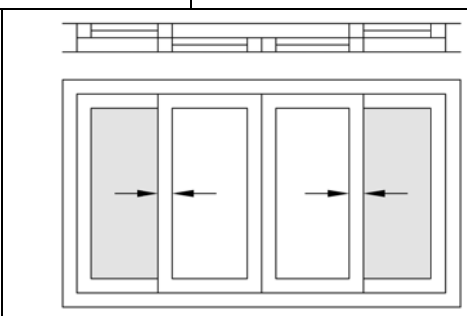
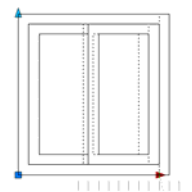

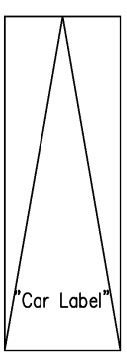
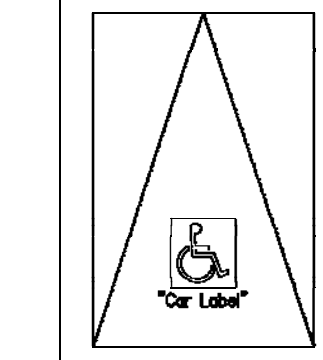
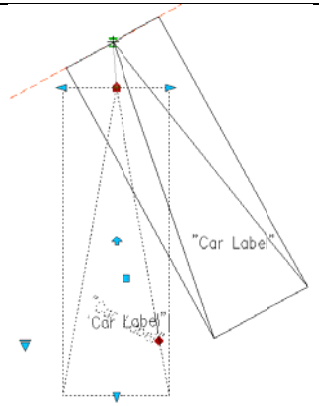

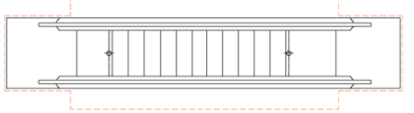
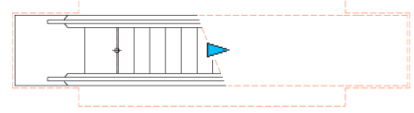
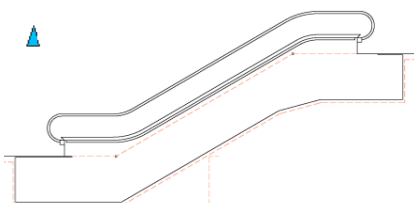
Block Description	Lookup Table Content			Actions
Door (Plan) 				
Door (Plan-Detail) 	Single (With multiple angle swing)	Single Swinging	Double Equal (With multiple angle swing)	
Door With Subframe (Plan-Detail) 				
	Double Non Equal		Double Swinging	 Door Width Stretch Action.
Standard Steel Door (Plan) 				 Wall Thickness Stretch Action.
	Single - Double Rebate (With multiple angle swing)	Double Equal - Double Rebate (With multiple angle swing)	Double NonEqual Double Rebate	
				 Opening Side Flip Vertically.
	Single - Single Rebate (With multiple angle swing)	Double Equal - Single Rebate (With multiple angle swing)	Double Non Equal Single Rebate	
Wrap-Around Steel Door (Plan) 				 Align From Door Center.
	Single - Wrap on 2 Sides (With multiple angle swing)	Double Equal - Wrap on 2 Sides (With multiple angle swing)	Double Non Equal Wrap on 2 Sides	
				
	Single - Wrap on 1 Side (With multiple angle swing)	Double Equal - Wrap on 1 Side (With multiple angle swing)	Double Non Equal Wrap on 1 Side	

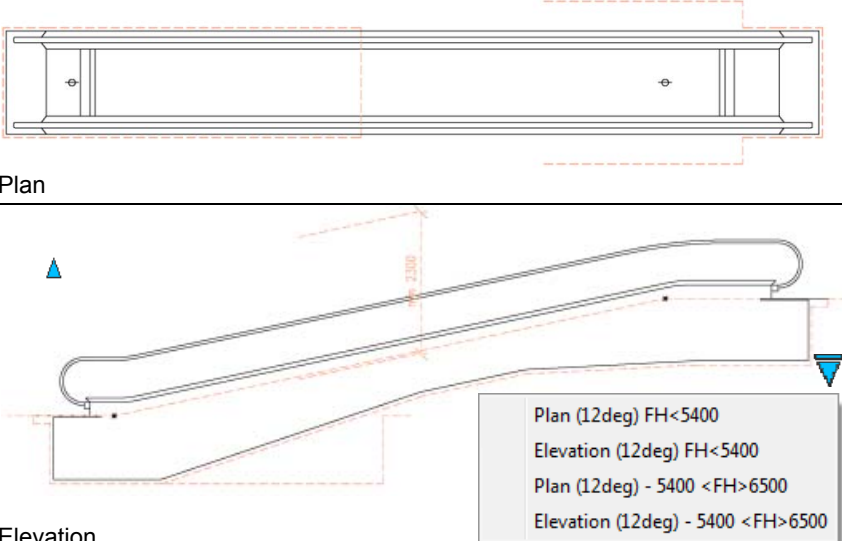
Block Description	Lookup Table Content	Actions
-------------------	----------------------	---------

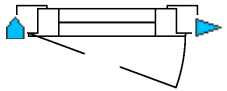
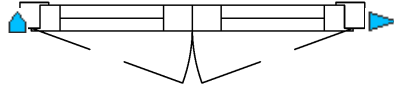
<p>Aluminium Window (Plan)</p> <hr/> <p>Aluminium Window (Elevation)</p>					 <ul style="list-style-type: none"> <li> Window Width Stretch Action.</li> <li> Align Block From Window's Center.</li> <li> Align From Window's Insertion.</li> </ul>
	Fixed	1 Panel	2 Panels	3 Panels (Type A)	
					 <ul style="list-style-type: none"> <li> Window Width Stretch Action.</li> <li> Window Height Stretch Action.</li> <li> Flip Vertically.</li> </ul>
	3 Panels (Type B)		4 Panels		

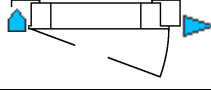
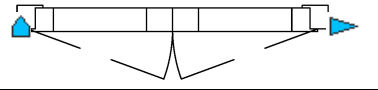
<p>Parking Car</p> <div style="border: 1px solid gray; padding: 5px; margin-top: 10px;"> <ul style="list-style-type: none"> <li>KSA 2500 x 5500 mm</li> <li>KSA 2600 x 5500 mm</li> <li>KSA 2500 x 6000 mm</li> <li><input checked="" type="checkbox"/> LEB 1800 x5200 mm</li> <li>LEB 1700 x4800 mm</li> <li>LEB for Disable</li> <li>Custom</li> </ul> </div>				<ul style="list-style-type: none"> <li> Car Width Stretch Action.</li> <li> Car Length Stretch Action.</li> <li> Parking Direction Flip Horizontally.</li> <li> Align Block to direction.</li> <li> Move Label.</li> <li> Rotate Label.</li> <li> Move Disabled Symbol</li> </ul>
-----------------------------------------------------------------------------------------------------------------------------------------------------------------------------------------------------------------------------------------------------------------------------------------------------------------------------------------------------------------	-------------------------------------------------------------------------------------	-------------------------------------------------------------------------------------	-------------------------------------------------------------------------------------	-----------------------------------------------------------------------------------------------------------------------------------------------------------------------------------------------------------------------------------------------------------------------------------

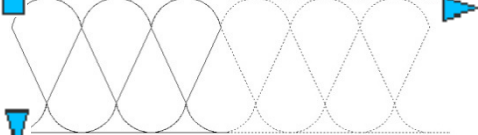









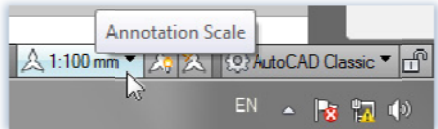

<p>Escalator</p> <p><b>N.B:</b></p> <ul style="list-style-type: none"> <li>- Escalator length depend from the floor height (HE) parameter.</li> <li>- Escalator types (<a href="#">Properties Lookup</a>) depend from the escalator angle 30 or 35 deg (<a href="#">Visibility Lookup</a>)</li> </ul> <p><i>Ref. Figure 1</i></p> <ul style="list-style-type: none"> <li>-  Indicative line for the concrete reservation (won't be plotted).</li> </ul>	<div style="border: 1px dashed gray; padding: 5px; margin-bottom: 5px;">  <p>Upper Plan</p> </div> <div style="border: 1px dashed gray; padding: 5px; margin-bottom: 5px;">  <p>Lower Plan</p> </div> <div style="border: 1px dashed gray; padding: 5px;">  <p>Elevation</p> </div>	<ul style="list-style-type: none"> <li> Floor Height, Stretch Action.</li> <li> Cut Line Limit in Lower Plan, Stretch Action.</li> </ul> <table style="width: 100%; border-collapse: collapse;"> <tr> <td style="width: 50%; border: 1px solid gray; padding: 5px;"> <p><b>Visibility Lookup</b></p> <ul style="list-style-type: none"> <li>Upper Plan (30 deg)</li> <li>Lower Plan (30 deg)</li> <li>Elevation (30 deg)</li> <li>Upper Plan (35deg)</li> <li>Lower Plan (35 deg)</li> <li>Elevation (35 deg)</li> </ul> </td> <td style="width: 50%; border: 1px solid gray; padding: 5px;"> <p><b>Properties Lookup</b></p> <ul style="list-style-type: none"> <li>2 Steps S600 (HE&lt;6000)</li> <li>2 Steps S800 (HE&lt;6000)</li> <li>2 Steps S1000 (HE&lt;6000)</li> <li>3 Steps S600</li> <li>3 Steps S800 (HE&lt;6000)</li> <li>3 Steps S1000 (HE&lt;6000)</li> <li>3 Steps S800 (HE&gt;6000)</li> <li>3 Steps S1000 (HE&gt;6000)</li> <li>Custom</li> </ul> </td> </tr> </table> <p style="text-align: center; margin-top: 10px;"><b>Figure 5</b></p> <div style="border: 1px solid gray; padding: 5px; margin-top: 10px; width: fit-content; margin-left: auto;"> <ul style="list-style-type: none"> <li>2 Steps S600</li> <li>2 Steps S800</li> <li>2 Steps S1000</li> <li>Custom</li> </ul> </div>	<p><b>Visibility Lookup</b></p> <ul style="list-style-type: none"> <li>Upper Plan (30 deg)</li> <li>Lower Plan (30 deg)</li> <li>Elevation (30 deg)</li> <li>Upper Plan (35deg)</li> <li>Lower Plan (35 deg)</li> <li>Elevation (35 deg)</li> </ul>	<p><b>Properties Lookup</b></p> <ul style="list-style-type: none"> <li>2 Steps S600 (HE&lt;6000)</li> <li>2 Steps S800 (HE&lt;6000)</li> <li>2 Steps S1000 (HE&lt;6000)</li> <li>3 Steps S600</li> <li>3 Steps S800 (HE&lt;6000)</li> <li>3 Steps S1000 (HE&lt;6000)</li> <li>3 Steps S800 (HE&gt;6000)</li> <li>3 Steps S1000 (HE&gt;6000)</li> <li>Custom</li> </ul>
<p><b>Visibility Lookup</b></p> <ul style="list-style-type: none"> <li>Upper Plan (30 deg)</li> <li>Lower Plan (30 deg)</li> <li>Elevation (30 deg)</li> <li>Upper Plan (35deg)</li> <li>Lower Plan (35 deg)</li> <li>Elevation (35 deg)</li> </ul>	<p><b>Properties Lookup</b></p> <ul style="list-style-type: none"> <li>2 Steps S600 (HE&lt;6000)</li> <li>2 Steps S800 (HE&lt;6000)</li> <li>2 Steps S1000 (HE&lt;6000)</li> <li>3 Steps S600</li> <li>3 Steps S800 (HE&lt;6000)</li> <li>3 Steps S1000 (HE&lt;6000)</li> <li>3 Steps S800 (HE&gt;6000)</li> <li>3 Steps S1000 (HE&gt;6000)</li> <li>Custom</li> </ul>			







Block Description	Lookup Table Content	Actions
<p>Moving - Walks</p> <p><u>N.B:</u>                      - The length depend from the floor height (FH) parameter.                      -  Indicative line for the concrete reservation (won't be plotted).</p>	 <p>Plan</p> <p>Elevation</p> <p>Plan (12deg) FH&lt;5400                      Elevation (12deg) FH&lt;5400                      Plan (12deg) - 5400 &lt;FH&gt;6500                      Elevation (12deg) - 5400 &lt;FH&gt;6500</p>	<p> Floor Height, Stretch Action.</p>
<p>Hinged Window</p>	 	<p> Window Width Stretch Action.</p>
<p>Hinged Shutter</p>	<p>1 Leaf </p> <p>2 Leaves </p>	<p> Align Block.</p>
<p>Thermal Insulation</p>		<p> Insulation Length Stretch Action.</p> <p> Insulation Thickness Stretch Action.</p>



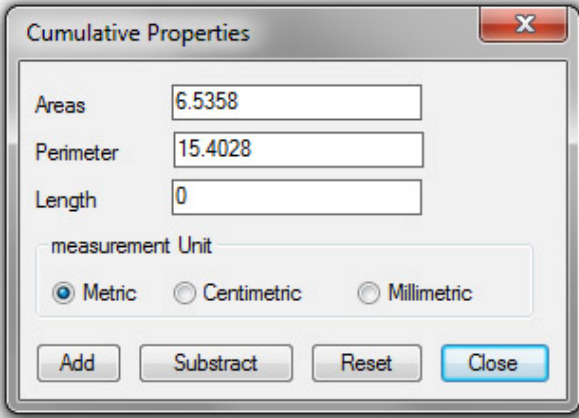

## 2. EG-Commands



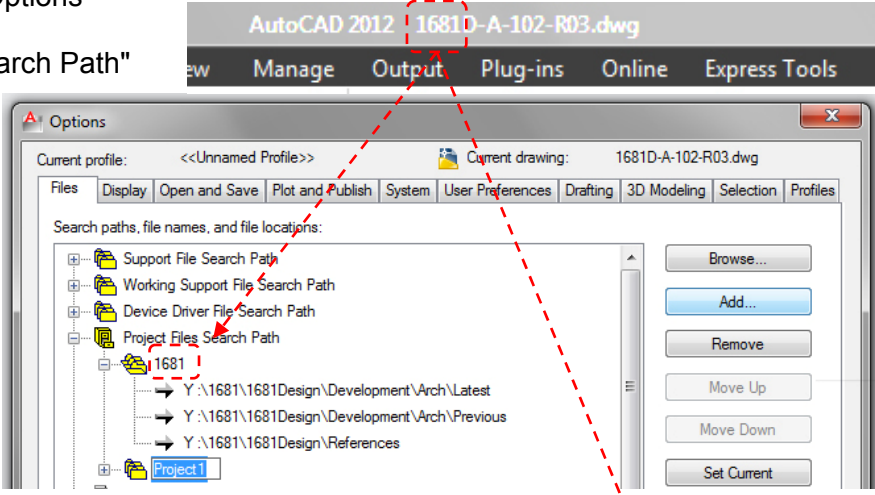









Commands	Description	Remarks
<b>DIMENSIONS</b>	Creates Dimensions with Erga DimStyle according to: <ul style="list-style-type: none"> <li>- the Drawing Units</li> <li>- the Discipline</li> <li>- the Annotation Scale</li> </ul>	<ul style="list-style-type: none"> <li>• Before using these tools don't forget to:                             <ul style="list-style-type: none"> <li>- Set the <b>Drawing Units</b> from the Tool Palettes.</li> <li>- Select the proper <b>Annotation Scale</b> for the drawing at the right bottom of the screen.</li> </ul> </li> </ul>  <ul style="list-style-type: none"> <li>• If even so the dimension command doesn't work properly:                             <ul style="list-style-type: none"> <li>- Go to the DimStyle Manager select the "ERGA-MM-100" style and rename it.</li> <li>- The Dimension command must be used <b>only from the Tool Palette the first time</b> in order to set current the right DimStyle .</li> </ul> </li> <li>• If you want to change the Drawing's Scale and its Annotation:                             <ul style="list-style-type: none"> <li>- Change the Annotation Scale</li> <li>- Create a new dimension (from the palette) in order to update the dimstyle</li> <li>- At the command prompt enter : <code>dim</code> ← ↵ <code>up</code> ← ↵ Select the dimension objects you want to update or enter: <code>all</code> to select all objects.</li> </ul> </li> </ul>
	 Creates linear dimensions: DIMLINEAR	
	 Creates an aligned linear dimension: DIMALIGNED	
	 Creates an angular dimension: DIMANGULAR	
	 Creates arc length dimensions: DIMARC	
	 Creates radius dimensions for circles and arcs: DIMRADIUS	
	 Creates diameter dimensions for circles and arcs: DIMDIAMETER	
<b>TEXT</b>	Creates Text or multileader with sizes relative to: <ul style="list-style-type: none"> <li>- the Drawing Units</li> <li>- the Discipline</li> <li>- the Annotation Scale</li> </ul> <p><u>N.B:</u> when we say 2mm we mean the printing size of the text on the layout.</p>	<ul style="list-style-type: none"> <li>• Before using these tools don't forget to:                             <ul style="list-style-type: none"> <li>- Set the <b>Drawing Units</b> from the Tool Palettes.</li> <li>- Select the proper <b>Annotation Scale</b> for the drawing at the right bottom of the screen.</li> </ul> </li> <li>• If you want to change the Drawing's Scale and its Annotation:                             <ul style="list-style-type: none"> <li>- Change the Annotation Scale</li> <li>- Create a new Text or Multi-leader (from the palette)</li> <li>- Match properties  the old Annotations with the new one created.</li> </ul> </li> </ul>
	 Text 2mm	
	 Text 4mm	
	 Text 4mm	
	 Draw Multileader 2mm Text	
	 Draw Multileader 4mm Text	

Commands	Description	Remarks
 <p>Cumulative Properties</p>	<p>Area, Perimeter, &amp; Length Calculator.</p> 	<ul style="list-style-type: none"> <li>• If the "Length" field value is "0" this means that all the polylines selected are closed.</li> <li>•  When calculating Areas and you find a value in the "Length" field, this means some of the polylines aren't closed and therefore their areas are excluded from the total Areas.</li> </ul>
 <p>Extended Trim</p>	<p><b>Cookie Cutter Trim:</b> Trims multiple line with single pick.</p> <ol style="list-style-type: none"> <li>1. Draw a polyline that intersects lines to be trimed</li> <li>2. Click the command and select the polyline.</li> <li>3. Click on the side of the lines to be trimed</li> </ol>	
 <p>ZERO</p>	<p>Changes Object's Elevation To Zero</p>	
 <p>XrefShadow</p>	<p>Changes layers colors of selected xrefs to a selected color.</p>	<p>This command is very useful for MEP trades to change architectural Xrefs Drawings onto a single color.</p>
 <p>SetProject</p>	<ul style="list-style-type: none"> <li>• In the AutoCAD's Options →"Files" Tab →"Project Files Search Path"</li> </ul>  <p>Autocad stores Folders paths for <b>Xrefs</b>.</p> <ul style="list-style-type: none"> <li>• The paths are sorted according to Project Name.</li> <li>• Each Drawing contains a PROJECTNAME variable.</li> </ul> <ul style="list-style-type: none"> <li>• The <b>SetProject</b> command reads the first 4 digit of my current drawing name and <b>automatically</b> : <ul style="list-style-type: none"> <li>- Creates in the "Project Files Search Path" a Project folder.</li> <li>- Stores the created PROJECTNAME in the current drawing.</li> </ul> </li> </ul> <p>Command: PROJECTNAME Enter new value for PROJECTNAME, or . for none &lt;"1681"&gt;:</p>	

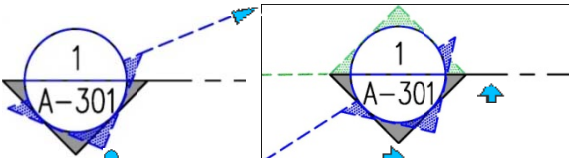









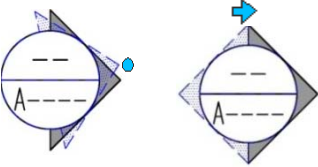

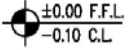
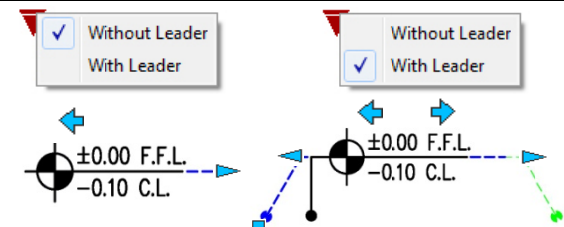
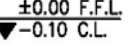
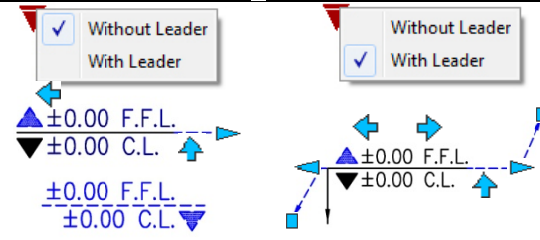
### 3. EG-Tags & Symbols

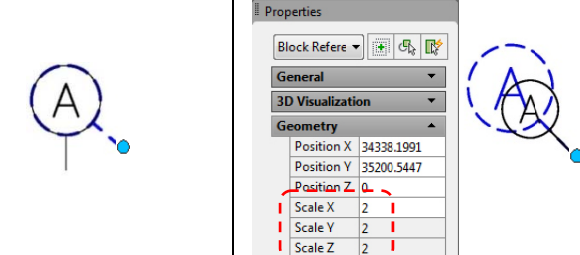



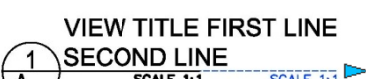

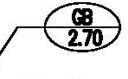
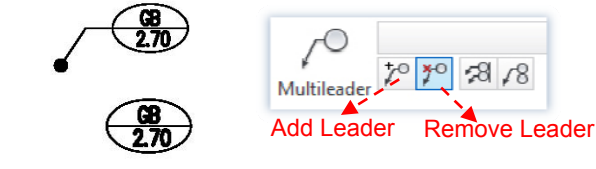

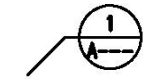

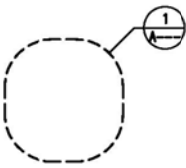

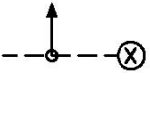
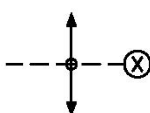
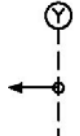
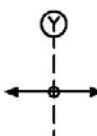
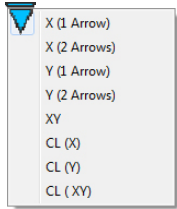
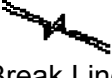
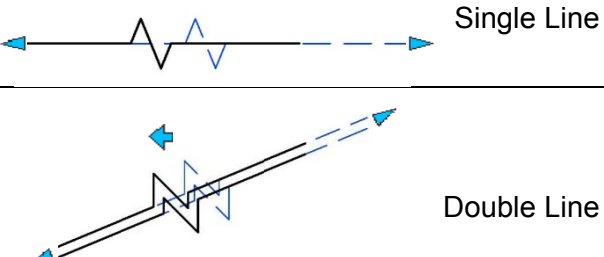
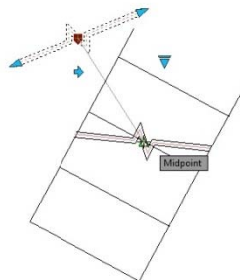

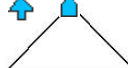
Tags & Symbols	Description & Lookup Table Content	Remarks & Actions
----------------	------------------------------------	-------------------

 All Tags and Symbols inserted from the Tools Palette are directly related to the settings and **Annotation Scale** of the drawing. At insert they will automatically take the proper **layer** and **scale size**.





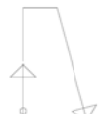





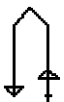
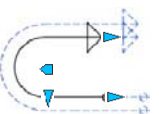
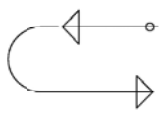

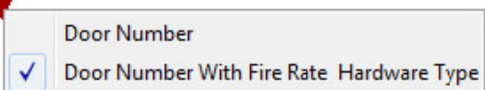
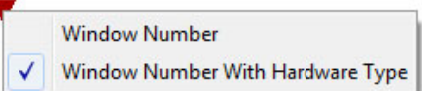

 <p>Insert Room Tag</p>	<ul style="list-style-type: none"> <li>This command inserts a Room Tag Block attached to a polyline (area boundary).</li> <li>The Area and Perimeter fields are attached to the selected polyline, once the polyline vertices are changed the Area and Perimeter values are updated automatically.</li> </ul> <p style="text-align: center;">                 NAME  <input type="text" value="REF"/>                  Area m<sup>2</sup>                  Perimeter m             </p>	<ul style="list-style-type: none"> <li> If the polyline and its attached Room Tag are copied, the new copied Tags will all be attached to the same <b>original</b> polyline. You need to update the Tags.</li> <li>After changing a polyline enter <b>REGENALL</b> in order to see the updated value in the Area &amp; Perimeter Fields</li> <li>If the Area &amp; Perimeter Values are <b>####</b> this means that the Tag has lost its attached polyline. You need to update the Tag (Refer to next Command: Update Room Tag)</li> <li>If you don't need the Area &amp; Perimeter fields just make the attributes invisible in the <i>Block Attribute Manager (BATTMAN)</i></li> </ul>
 <p>Update Room Tag</p>	<p>This command attaches an existing Room Tag to a selected Polyline and updates its fields values.</p>	
 <p>Coordinates Tag</p>	<ul style="list-style-type: none"> <li>This Tag displays the Northing &amp; Easting Coordinates at the insertion point of the Tag.</li> <li>Once the block location is changed the coordinates updates automatically after regeneration.</li> </ul>	<ul style="list-style-type: none"> <li>The Values Units are In Meter.</li> <li>The values are automatically calculated according to the Drawing units (M or MM from the settings).</li> </ul>
 <p>Numbering Tag</p>	<ul style="list-style-type: none"> <li>Inserts Sequence Numbers for Stair Risers or Parking cars...</li> <li>You can insert each Tag consequently or use the [A]rray option.</li> </ul>	<p>When using the command follow On Screen the command line to select the numbering options.</p>
 <p>Tags Renumbering</p>	<ul style="list-style-type: none"> <li>Renumbers All Tags with Attributes: Stairs Numbers, Room Tags, Grid Tags, etc...</li> </ul>	<p><u>Procedure:</u></p> <ol style="list-style-type: none"> <li>1. Draw a <u>polyline</u> that <u>crosses</u> consequently above all tags to be renumbered.</li> <li>2. Select the <b>text attribute</b> to be renumbered. (NB: not the block lines)</li> <li>3. Finally the tool will ask for a <i>suffix or prefix</i> and a starting <i>sequence number</i>.</li> </ol>
 <p>Section Tag</p>		<ul style="list-style-type: none"> <li> Stretch section line</li> <li> Rotate Tag (label always horizontal)</li> </ul>
 <p>Wall Section Tag</p>		<ul style="list-style-type: none"> <li> Flip Section line and Arrow direction</li> <li></li> </ul>

Tags & Symbols	Description & Lookup Table Content	Remarks & Actions
----------------	------------------------------------	-------------------

 <p>Elevation Tag</p>		<ul style="list-style-type: none"> <li>Rotate Arrow (label always horizontal).</li> <li>Flip Arrow direction.</li> </ul>
 <p>Internal Elevation Tag</p>		<ul style="list-style-type: none"> <li>Rotate Arrow (label always horizontal).</li> <li>Flip Arrow direction.</li> </ul>
 <p>Level Indicator in plan</p>		<ul style="list-style-type: none"> <li>Stretch Line</li> <li>Flip Leader Side</li> <li>Flip Tag Horizontally</li> <li>Polar Stretch Leader</li> </ul>
 <p>Level Indicator in Section</p>		<ul style="list-style-type: none"> <li>Stretch Line</li> <li>Flip Leader Side</li> <li>Flip Tag Horizontally</li> <li>Flip Arrow Side(Top-Bottom)</li> <li>Polar Stretch Leader</li> </ul>
 <p>Grid Tag</p>		<ul style="list-style-type: none"> <li>Rotate the tag Tail and the <b>Insertion Point Position</b> of the block.</li> <li>⚠ When changing the X,Y,Z, scale properties of a block, the block will be scaled according to its insertion point.</li> </ul>
 <p>View Title</p>		<ul style="list-style-type: none"> <li>Stretch Line</li> </ul>
 <p>View Title With Cross Reference</p>		<p>The View Title is a "Multiline Attribute" to edit the Title: Double Click the text than Press  to open the multiline editor.</p>
 <p>Level Indicator for reflected ceiling plan</p>		<p>These Tags are "multileader" and can be edited with the "Multileader Editing Tools"</p>
 <p>Detail Indicator</p>		<p>Command: MLEADEREDIT Ribbon: ANNOTATE → LEADER</p>

Tags & Symbols	Description & Lookup Table Content				Remarks & Actions
 <p>Callout</p>	<p>Draws Callouts (rectangle with filleted angles). Fillet radius depend from the drawing's Annotation Scale.</p> 				<ul style="list-style-type: none"> <li>⚠ When changing the drawing's "Annotation Scale" the existing callouts won't change their fillet radius automatically, callouts must be redrawn in order to update their radius.</li> <li>After drawing the callout add the "Detail Indicator"</li> </ul>
 <p>Tiling Start Point</p>	 <p>X (1 Arrow)</p>	 <p>X (2 Arrows)</p>	 <p>Y (1 Arrow)</p>	 <p>Y (2 Arrows)</p>	<ul style="list-style-type: none"> <li>Align to tiles direction.</li> <li>Stretch lines.</li> <li>Flip Horizontally or vertically (text always readable).</li> </ul> 
 <p>Break Line Symbol</p>	 <p>Single Line</p> <p>Double Line</p>				<ul style="list-style-type: none"> <li>Stretch Break Line (Break Symbol Always Centered)</li> <li>Flip</li> </ul> 
 <p>Stair Arrow</p>					<ul style="list-style-type: none"> <li>Flip</li> <li>Align to stair direction.</li> </ul>
 <p>Stair Start Point</p>					
 <p>Stair Line Arrow-1</p>	 <p>1 Arrow</p>	 <p>2 Arrows</p>	 <p>U Stair (1 Arrow)</p>	 <p>U Stair (2 Arrow)</p>	<ul style="list-style-type: none"> <li>Align to stair direction.</li> <li>Stretch Arrow Line.</li> <li>Flip according to stair middle.</li> <li>Flip according to stair start point.</li> <li>Stretch in any direction.</li> </ul>
	 <p>Polygonal Stair (1 Arrow)</p>	 <p>Polygonal Stair (2 Arrow)</p>	 <p>L Stair (1 Arrow)</p>	 <p>L Stair (2 Arrow)</p>	

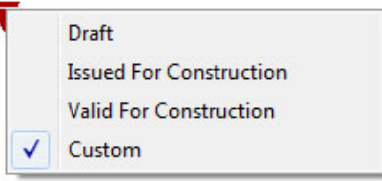
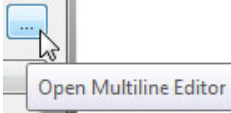
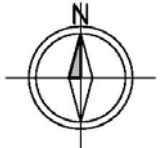
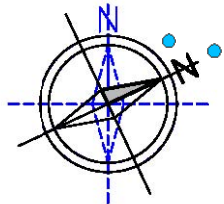

Tags & Symbols	Description & Lookup Table Content		Remarks & Actions
 <p>Stair Line Arrow-2</p>	 <p>1 Arrow</p>	 <p>2 Arrows</p>	<ul style="list-style-type: none"> <li>Align to stair direction at curve center point.</li> <li>Stretch Line.</li> <li>Change stair width.</li> </ul>
 <p>Door Tag</p>	 <p>Door Number with Fire Rate &amp; Hardware Type</p>  <p>Door Number</p>		   <p>When Switching from Door Number or Window Number to the one with Fire Rate &amp; Hardware Type if the attributes values are filled they may look overlaped like the previous figure:</p>
 <p>Window Tag</p>	 <p>Window Number With Hardware Type</p>  <p>Window Number</p>		<ul style="list-style-type: none"> <li>You can empty it by deleting the attributes values.</li> <li>If the change must be applied to all the drawing go to <i>Block Attribute Manager</i> (command: <i>Battman</i>) and make the Fire Rate &amp; Hardware Attributes <i>Invisible</i></li> </ul>
 <p>Louver Tag</p>	 <p>Closet Tag</p>	 <p>Painting Tag</p>	 <p>Finishes Tag</p>
 <p>Stamp</p>	 		<ul style="list-style-type: none"> <li>Stretch to change the stamp size</li> <li>The Lookup Table contains 3 predefined stamps.</li> <li>In the <i>Custom</i> option the Stamp Attribute is a <i>multiple lines attribute</i> open the <i>Multiline Editor</i> in order to edit the value.</li> </ul> 
 <p>North Symbol</p>			<ul style="list-style-type: none"> <li>Rotate the North Symbol</li> <li>Rotate the N text</li> </ul>

Tags & Symbols	Description & Lookup Table Content	Remarks & Actions
----------------	------------------------------------	-------------------



Graphic Scale (m)

<p>SCALE - METER 1/1</p>	<p>SCALE - METER 1/2</p>	<p>SCALE - METER 1/5</p>
<p>SCALE - METER 1/10</p>	<p>SCALE - METER 1/20</p>	<p>SCALE - METER 1/25</p>
<p>SCALE - METER 1/100</p>	<p>SCALE - METER 1/200</p>	<p>SCALE - METER 1/50</p>
<p>SCALE - METER 1/1000</p>	<p>SCALE - METER 1/2000</p>	<p>SCALE - METER 1/500</p>
<p>SCALE - METER 1/75</p>	<p>SCALE - METER 1/250</p>	<p>SCALE - METER 1/5000</p>

- 1/5000
- 1/2000
- 1/1000
- 1/500
- 1/250
- 1/200
- 1/100
- 1/75
- 1/50
- 1/25
- 1/20
- 1/10
- 1/5
- 1/2
- 1/1

- Graphic Scale should only be inserted in **paper space** (on the layout)
- After the insertion choose from the LookUp table the proper scale.
- The scale written in pink below the Graphic Scale is only for visual reference and won't be printed.
- The Graphic Scale indications are in **meter** (1=1m)









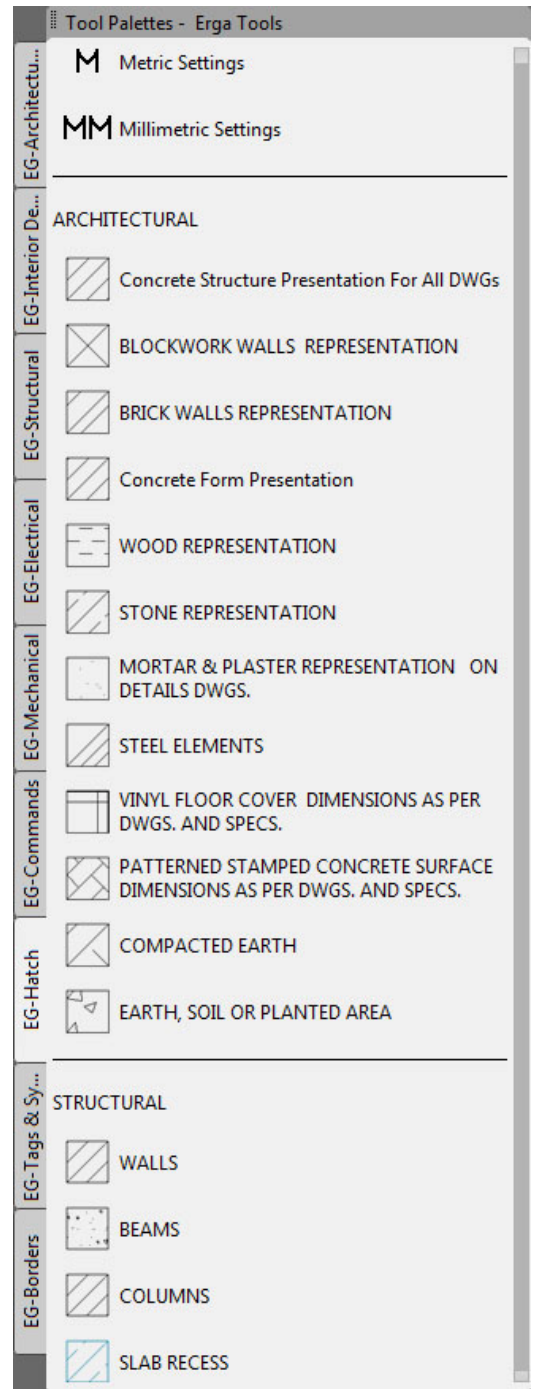







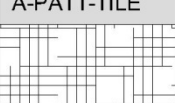

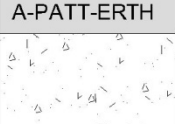



#### 4. EG-Hatch Patterns

- EG-Hatches Tools includes standard hatch patterns for Architectural and Structural disciplines.
- Before using the hatch tools don't forget to arrange the file settings: units and scale. (Refer to *SETTINGS* page 21)
- All hatches used from the palettes will have the proper Layer and the proper scale (according to the Annotation Scale of the drawing).
- To use the Hatch Tool, pick the desired tool and then pick inside the area to be filled with hatch.

 Refer to next page for the Architectural Hatch Patterns.

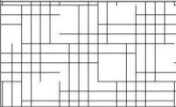

ARCHITECTURAL HATCH PATTERNS MILLIMETRIC BASED DWGS			DRAWING SCALE					
			1/200 1/100	1/50 1/20	1/10 1/5	1/2 1/1		
HATCH LAYER	DESCRIPTION	$\alpha = 0$	HATCH SCALE					
A-PATT-CONC	ANSI 31	$\alpha = 0$	40	10	2	0.4		
	CONCRETE STRUCTURE REPRESENTATION FOR ALL DWGS.		20	4	1	0.2		
A-PATT-BLWO	ANSI 37	$\alpha = 0$						
	BLOCKWORK WALLS REPRESENTATION							
A-PATT-BRCK	ANSI 37	$\alpha = 0$						
	BRICK WALLS REPRESENTATION							
A-PATT-WOOD	DASH	$\alpha = 0$						
	WOOD REPRESENTATION							
A-PATT-STON	ANSI 33	$\alpha = 0$						
	STONE REPRESENTATION							
A-PATT-MRTR	AR-SAND	$\alpha = 0$						
	MORTAR & PLASTER REPRESENTATION ON DETAILS DWGS.							
A-PATT-STEL	ANSI 34	$\alpha = 0$						
	STEEL ELEMENTS							
A-PATT-TILE	HOUND	$\alpha = 0$						
	VINYL FLOOR COVER DIMENSIONS AS PER DWGS. AND SPECS.							
A-PATT-TILE	AR-HBONE	$\alpha = 0$						
	PATTERNED STAMPED CONCRETE SURFACE DIMENSIONS AS PER DWGS. AND SPECS.							
A-PATT-ERTH	EARTH	$\alpha = 45$						
	COMPACTED EARTH							
A-PATT-ERTH	AR-CONC	$\alpha = 0$						
	EARTH, SOIL OR PLANTED AREA							
			4	0.8	0.2	0.04		

ARCHITECTURAL HATCH PATTERNS METRIC BASED DWGS			DRAWING SCALE							
			1/200	1/100	1/50	1/20	1/10	1/5	1/2	1/1
HATCH LAYER	DESCRIPTION		HATCH SCALE							
A-PATT-CONC	ANSI 31	$\alpha = 0$	0.04	0.01	0.002	0.0004				
	CONCRETE STRUCTURE REPRESENTATION FOR ALL DWGS.		0.02	0.004	0.001	0.0002				
A-PATT-BLWO	ANSI 37	$\alpha = 0$			0.006	0.0012				
	BLOCKWORK WALLS REPRESENTATION			0.012	0.003	0.0006				
A-PATT-BRCK	ANSI 37	$\alpha = 0$			0.003	0.0006				
	BRICK WALLS REPRESENTATION			0.006	0.0015	0.0003				
A-PATT-WOOD	DASH	$\alpha = 0$			0.002	0.0004				
	WOOD REPRESENTATION			0.004	0.001	0.0002				
A-PATT-STON	ANSI 33	$\alpha = 0$			0.002	0.0004				
	STONE REPRESENTATION			0.004	0.001	0.0002				
A-PATT-MRTR	AR-SAND	$\alpha = 0$			0.0002	0.00004				
	MORTAR & PLASTER REPRESENTATION ON DETAILS DWGS.			0.0004	0.0001	0.00002				
A-PATT-STEL	ANSI 34	$\alpha = 0$			0.002	0.0004				
	STEEL ELEMENTS			0.004	0.001	0.0002				
A-PATT-TILE	HOUND	$\alpha = 0$			0.040	0.008	0.0016			
	VINYL FLOOR COVER DIMENSIONS AS PER DWGS. AND SPECS.		0.080	0.016	0.004	0.0008				
A-PATT-TILE	AR-HBONE	$\alpha = 0$	0.0024	0.0006	0.00012	0.000024				
	PATTERNED STAMPED CONCRETE SURFACE DIMENSIONS AS PER DWGS. AND SPECS.		0.0012	0.00024	0.00006	0.000012				
A-PATT-ERTH	EARTH	$\alpha = 45$	0.096	0.024	0.0048	0.00096				
	COMPACTED EARTH		0.048	0.0096	0.0024	0.00048				
A-PATT-ERTH	AR-CONC	$\alpha = 0$	0.008	0.002	0.0004	0.00008				
	EARTH, SOIL OR PLANTED AREA		0.004	0.0008	0.0002	0.00004				





## E. ERGA ANNOTATIVE TOOLS

The **Erga Annotative Tools** is similarly organized as the **Erga Tools** with the only difference that objects contained in the palettes are **Annotative Objects**.

### 1. ANNOTATIVE OBJECTS

- *Annotative Property* is applied only on Annotations.
- Annotations are objects commonly used to annotate the drawing like:

- Hatches
- Text (single-line and multiline)
- Tables
- Dimensions
- Tolerances
- Leaders and multi leaders
- Blocks
- Attributes

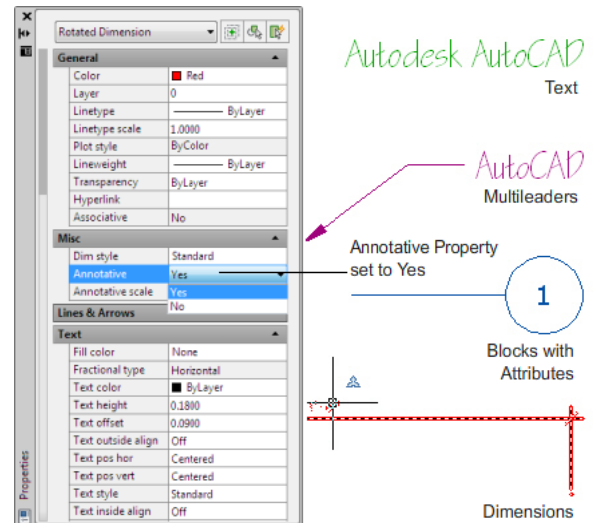

Figure 6

- Annotative objects are automatically scaled, base to the current *Annotation Scale* setting (Refer to Annotation Scale page 22) and are automatically displayed at the correct size.
- The Annotative Property can be generalized **By Style** or by changing the "Annotative Property" of a specific object in the **Properties Palette** (Figure 8)

### 2. HANDELING DRAWINGS WITH MULTIPLE SCALES

#### Annotation Object Scale List

- An annotative object can support several annotation scales for views at different scales. You can add or delete scales from the Object scale list assigned to the selected annotative object in the *Annotation Object Scale* (Figure 7)

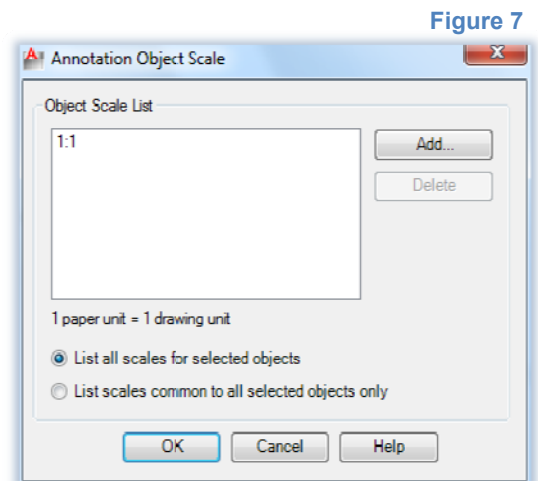

Figure 7

To open *Annotation Object Scale*:



Ribbon: Go to *Annotate* → *Annotation Scaling* → *Add / Delete Scales*.

or AutoCAD Classic: *Modify* → *Annotative Object Scale* → *Add/Delete Scales*.

or Command Line: **objectscale**.

or From the object properties: Select the annotation → Go to *Properties* → *Misc* → *Annotative Scale* → Press to open the Object Scale List (Figure 8).

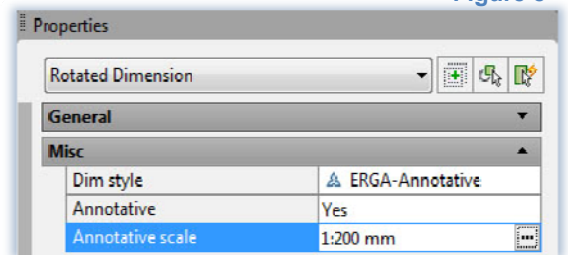
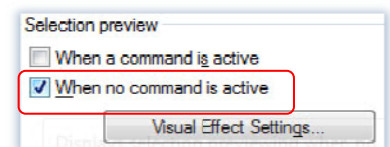



Figure 8

- When you hover the cursor over an annotative object that supports one annotation scale, the cursor displays a icon. When the object supports more than one annotation scale, it displays a icon. In case the icon isn't displayed go to:

*Options* (Shortcut "op") → *Selection* → *Selection preview* → Check "When no command is active".





- To automatically update annotative objects to support the current annotation scale:

On the drawing status bar, click the button  so it displays as .

So every time you change the annotation scale, the current scale will be added automatically to **all annotative objects scale lists in the drawing** including **all annotative objects nested in blocks and Xrefs.**



When the drawing contains Xrefs having different units and containing annotative objects, (ex: your current drawing is with millimetric settings and contains Xrefs with metric settings), if the button display is  and you change the annotation scale, all annotation inside blocks or Xrefs will be displayed with an abnormal size (too big, or small) this is because the annotation scale settings differ from millimetric to metric settings ( refer to Annotation Scale page22). So you have to be careful before using the  button.

It would be better to turn off  the "annoautoscale" while using drawings with Xrefs files, or unload Xrefs before using it and than reload.

- To edit Object Scale List of nested object:
  - Open Block or Reference in Block Editor (**bedit** command) or in place Edit Reference (**refedit** command)
  - Select the nested annotative objects and edit its object scale list.
  - For external References you can open the Xref edit its object's scale list, save and reload.

### Annotation Object's Location

- The location of each scale representation of an annotative object can be adjusted using grips.

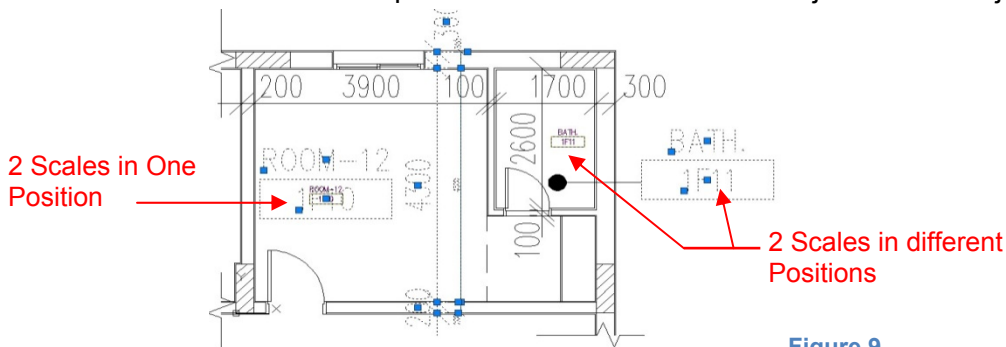

Figure 9

Once an annotation is selected, alternate scale representations (different scales and locations) are temporarily displayed in a dimmed state. (Figure 11)



- The **ANNORESET**, resets the locations of all alternate scale representations of the selected annotative objects.



Ribbon: Annotate tab → Annotation Scaling panel → Sync Scale Positions

or Menu: Modify → Annotative Object Scale → Synchronize Multiple-Scale Positions

or Shortcut menu: Select an annotative object. Right-click and choose Annotative Object Scale → Synchronize Multiple-Scale Positions.

or Command Line: **annoreset**

### Annotation Visibility

- When Annotation Visibility is turned on , all annotative objects are displayed.
- When annotation visibility is turned off , only annotative objects for the current scale are displayed. (see next example)

(N.B: The Annotation Visibility is found at the right side of the Status Bar).

#### Example of a single drawing printed in different statuses

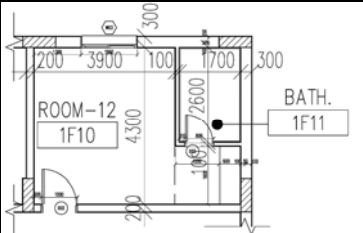

- Annotation Visibility is turned on.
- The Door & Window Tags don't have in their *Object Scale List* the 1:200mm that's why their size doesn't much the *Annotation Scale*.

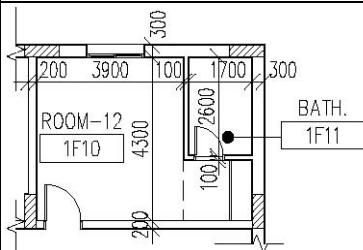

- Annotation Visibility is turned off.
- All apparent Annotations sizes matches the *Annotation Scale*.

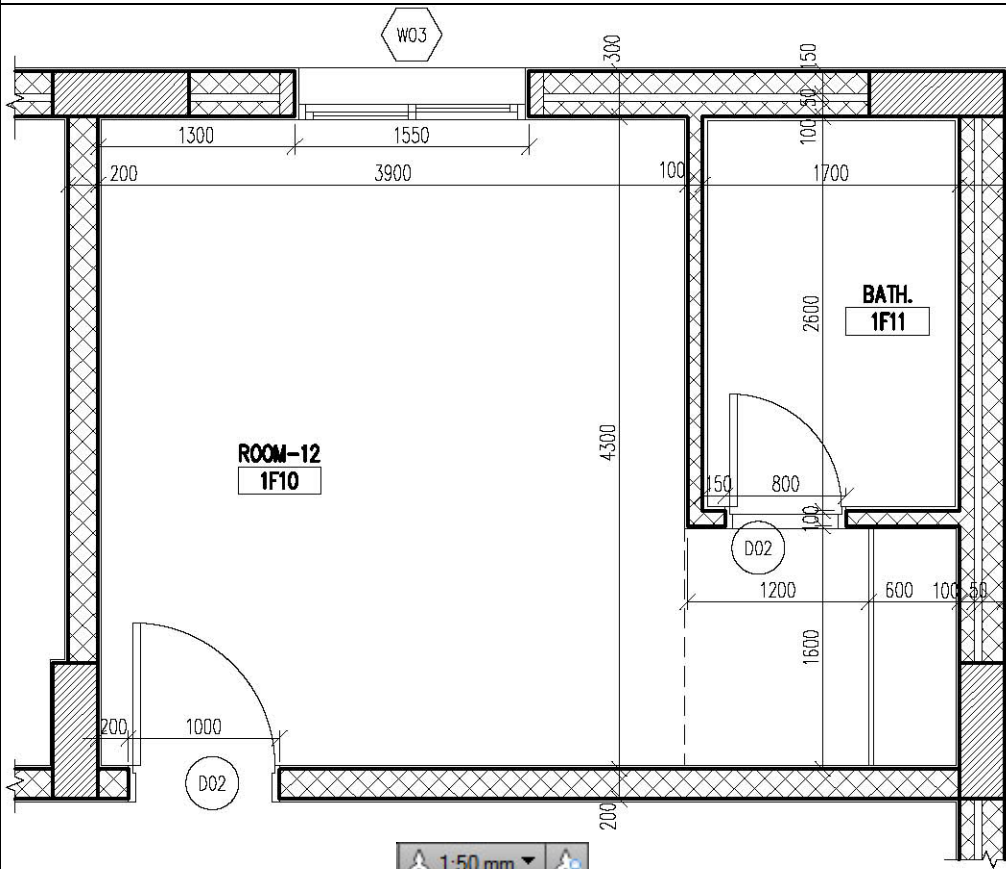

- Annotation Visibility is turned off.
- All apparent Annotations sizes matches the *Annotation Scale*.
- The Door & Window Tags are apparent at the proper size.
- The leader of the Room Tag (1F11) disappeared (it's object scale list doesn't include the 1:50mm scale).







## **IV. DRAFTING CONVENTIONS**





## IV. DRAFTING CONVENTIONS

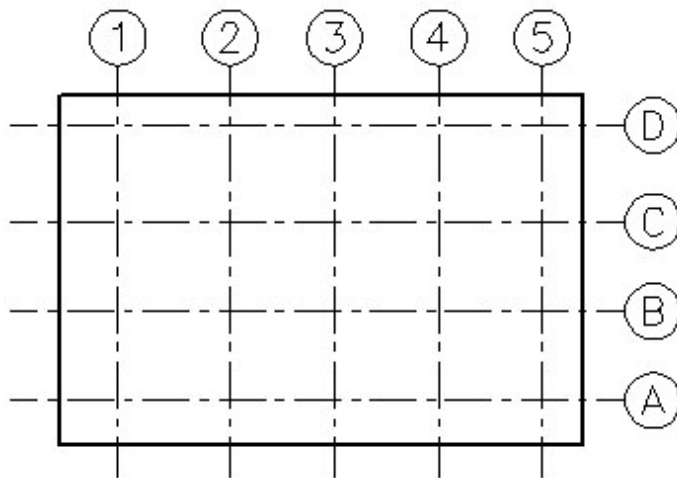

### A. GRID LINES

**Vertical grid lines:** located across the top and are numbered from left to right.

**Horizontal grid lines:** located to the right and are alphabetized from bottom to top.

### B. PLANS

#### Floor Plans

The following list of items should be included on all Architectural floor plans:

- Room names and numbers.
- Floor plan dimensions. Locate walls and partitions, level changes, and close strings of dimensions from column grid to column grid.
- Partition types.
- Borrowed light and louver types. Show exterior window types in small projects.
- Exterior and interior wall elevation references.
- Building section references.
- Wall section references.
- Floor plan horizontal detail references.
- Termination of floor materials within a room.
- Floor drain and slope lines of drainage to floor drain. Show extent and direction of slope.
- Plumbing fixtures, fire hose, and extinguisher cabinets.
- Built-in casework, shelving, lockers, benches, kitchen casework, and equipment.
- Openings in the floor such as elevator and dumbwaiter shafts, mechanical / plumbing/ electrical shafts, atria, stairs, and escalators. Do not show an "X" through a chase unless entire chase is a floor penetration.
- Trenches and other recessed areas needing depressions in the floor, such as recessed floor mats, thickset ceramic tile, and other items. Dimension and details each.
- References to details and sheet notes.
- Significant overhead features such as balconies, skylights, beams, and roof overhangs. Indicate with a dashed line and add a note describing what that line represents.
- Edge of slabs, ledges, equipment pads, and curbs. Do not show walls and bridges at the next level below, or items that appear on another floor or roof plan. Make sure that the structural drawing set contains the details required to illustrate these items.

## Reflected Ceiling Plans

- References to details for ceiling edge conditions, building expansion, control joints and seismic joints, and lighting coves. Do not reference building or wall section cuts.
- Description of exterior soffit materials. Include light fixtures, control joints, and access panels.
- Ceiling material indications. If more than one material is scheduled, show extent of materials. Place the ceiling component legend on the reflected ceiling plans rather than in the general information sheet.
- Light fixtures, exit lights, sprinkler heads, supply and return grilles, smoke detectors, speakers, emergency shower, and other items. Dimension if necessary.
- Ceiling access panels including panels that are furnished by mechanical or electrical trades. Indicate size.
- Rated partitions and other partitions extending through the ceiling plane to the structural deck. Identify rated partitions by a symbol.
- Skylights and roof hatches. Dimension if necessary.
- Plenum barriers where required by code.
- Elements located above ceilings requiring specific locations or construction such as fire-rated horizontal enclosures, catwalks, disappearing stairs, air handling equipment, and other elements.
- Delete door swings and door openings unless opening extends to the ceiling.

## Roof Plans

- Extent and direction of slope to roof drains. Show emergency roof overflow drains or scuppers. Include elevations of high points, ridges, low points, drains, and over flows for accurate determination/ confirmation of roof slope.
- Penthouse roof plan. Show on the same drawing if possible.
- Roof pavers, walking surfaces, changes in materials, building expansion, and roofing control and seismic joints.
- Antennas and supports, lightning arresters, major roof penetrations, window cleaning equipment, roof-mounted equipment, and screen walls. Coordinate lightning protection locations with Electrical.
- Skylights.
- Size and locate downspouts and gutter expansion joints for buildings with hipped roofs.
- Splash blocks at downspouts that discharge water onto a lower roof level.
- Roof access and ladders to different levels.
- Roof crickets.
- References to details for the items listed above. Do not detail parapets if shown on the wall sections.
- Eliminate conflict between roof penetrations (i.e. vents, exhausts) and roof crickets, flashing, and valleys. Consider relocating penetrations to less visible areas.

## Interiors Plans

The following list of items should be included on all Interior floor plans:

- Borrowed light and louver openings.
- Interior room elevation references.
- Pertinent tables, schedules, key, and sheet notes.
- Building expansion and seismic joints if they intersect and affect furniture and equipment installations.
- Trenches and other recessed areas with depressions.
- Fire hose cabinets that contain fire extinguishers, extinguisher cabinets, and wall mounted extinguishers. Coordinate locations with Architectural and Fire Protection plans.
- Drinking fountains, water coolers, and all other plumbing fixtures.
- Toilet partitions, toilet casework, and toilet accessories.

Guidelines for Interior Plans:

- Indicate rooms with equipment or custom furniture or other areas to be enlarged by a dashed line around the area. Reference to enlarged plan. Show furniture and equipment on enlarged plan only. Do not duplicate information shown on smaller scale plans. Show interior elevation references on the enlarged plan.
- Coordinate location of furniture and equipment with lockers, cabinets, chalkboards, tack boards, electrical outlets, thermostats, clock outlets, and other items contained in the Architectural / Engineering documents.
- Identify each item of furniture and equipment by a mark number.

Classifications of Furniture, Fixtures, and Equipment

- **Class 1:** Permanently fixed items with permanent utility connections, such as stoves, dishwashers, steam tables, light fixtures, wall switches, water chillers, air handling units, bridge cranes, pumps, electrical generators, transformers, and switch gear; and large fixed shop equipment such as automatic cutting machines, air compressors, jib cranes, large cleaning and plating tanks, and milling machines.
- **Class 2:** Portable items with flexible or quick-disconnect utility connections, including office and household items such as computers, calculators, electric coffee pots, vacuum cleaners, table lamps, floor lamps, window air conditioning units, household refrigerators, and television sets; and shop equipment such as powered hand drills (electric and pneumatic), powered hand-held saws, air compressors, welding machines, oxyacetylene cutting and welding outfits, and paint sprayers.
- **Class 3:** Movable items without utility connections, including office and household furnishings such as chairs, sofas, stands, desks, tables, rugs, beds, and shop equipment such as tool cabinets, work benches, storage racks, storage bins, storage shelves, bench-mounted vises, hand-powered trucks for handling compressed gas tanks, and A-frame cranes.
- **Class 4:** Expendable and consumable items, including expendables such as window curtains, shower curtains, bed linens, uniforms, clothing, brooms, wall mirrors, wall pictures, tableware, crystal ware, kitchen cutlery, cooking utensils, hand tools (pliers, screwdrivers, wrenches), mechanics' tool kits, test equipment (small battery-powered, hand-held voltmeters and multi-meters), and storage aids (Plastic storage bins and shelf separators); and consumables such as products with limited shelf life (medicines, chemicals, paints and food), household supplies (soaps, cleansers, and ammonia solutions), office supplies, shop supplies (nuts, bolts, welding rods, fluxes, electrical tape), janitorial supplies (wiping cloths, paper towels, toilet paper, and oil absorbent sweeping materials).

**C. ELEVATIONS**

Drawing an elevation as a direct projection from the plan, even for oblique or curved surfaces, is normal for schematic design drawings. However, this method is not suitable for design development and construction drawings. Curved elevations should be shown as if they are flat and identified as "straightened". The same approach applies to partial elevations forming an angle to the main elevation. These should be identified as "unfolded". Drawing the elevations in this manner depicts openings and other features in their true dimensions. (Figure 04.31)

If design development elevations are upgraded directly from the schematic design drawings, delete all graphics depicting people and cars as well as any shadows and shading that may be shown on the original drawings.

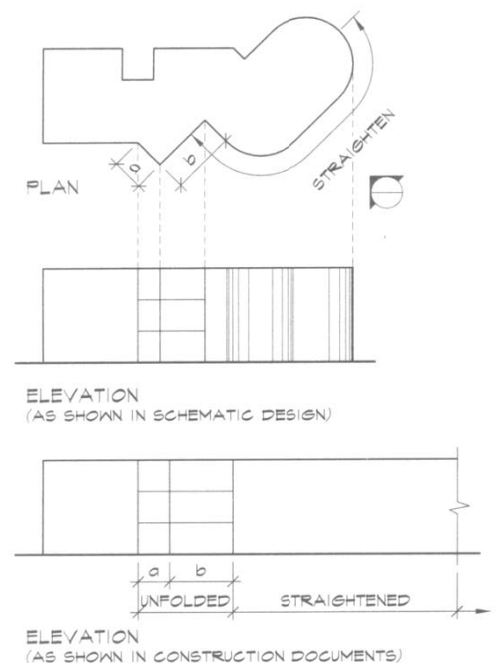

Figure 04.31 How to represent an elevation for the different phases.

The following list of items should be included on all exterior elevation drawings:

- Key Plan. Indicate locations of exterior elevations.
- Column grid lines, and match lines, if used.
- Scale. Indicate scale on all architectural exterior elevations (and partial exterior elevations).
- Building section references, if not shown on plans.
- Wall section references, if required by project complexity.
- Typical type and extent of materials, tie holes, and rustication joint patterns, and fenestration.
- Floor-to-floor dimensions.
- Extent of building elements below grade. Represent with dashed lines. (Figure 04.32)
- Gutters, rain leaders or downspouts, and roof scuppers labeled as to function.
- All penthouses, skylights, roof-mounted equipment extending above the parapet, mechanical louvers, or equipment screens. Do not indicate size of equipment.
- Ladders to roofs.
- Building identification graphics.
- Handrails and guardrails.
- Dock bumpers.
- Site adjacency elements such as retaining walls.
- Typical and non-typical detail references.
- Hidden and partial elevations.
- Lintels and shelf angles. Show dashed.
- Expansion and control joints for cement plaster and concrete masonry. Show extent of different cement plaster textures.
- Extent of different unit masonry bond patterns, colors, and textures.
- Movement joints, rustication joints, building expansion joints, and seismic joints. Coordinate with Structural plans.
- Form and tie patterns for architectural concrete.
- Light fixtures and signage.

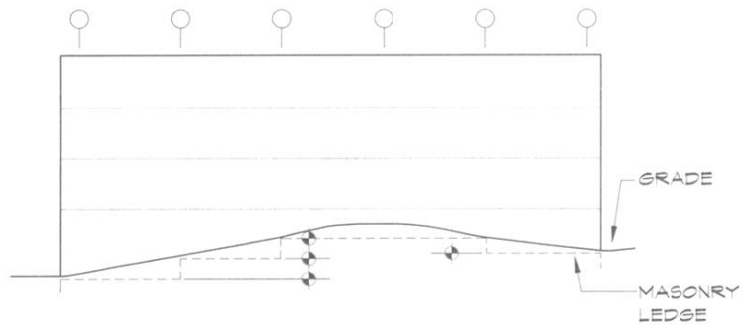

Figure 04.32 Elevation at grade.

### Interior Elevations

The following list of items should be included in all interior elevations:

- Access panels including those furnished by Mechanical and Electrical plans. Indicate size.
- Louvers and grilles. Coordinate sizes with Mechanical plans.
- Electrical switchgear and panels.
- Large pipe and duct penetrations.
- Changes in wall materials including acoustical applications.
- Door and borrowed light heights. Coordinate with coursing of masonry walls.
- Vertical dimensions and, in some cases, horizontal dimensions if not shown on the plans.
- Power, telephone, data, and other outlets around casework, equipment, furnishings, and other places where the location is critical.

Guidelines for Interior Elevations:

- Coordinate extent of cabinets with Interiors and Equipment drawings.
- Indicate and locate by dimension expansion, seismic, masonry, and plaster control joints.
- If more than one material is scheduled for a room's wall, its extent should be graphically shown and dimensioned.
- Indicate and dimension location of wall sconces.

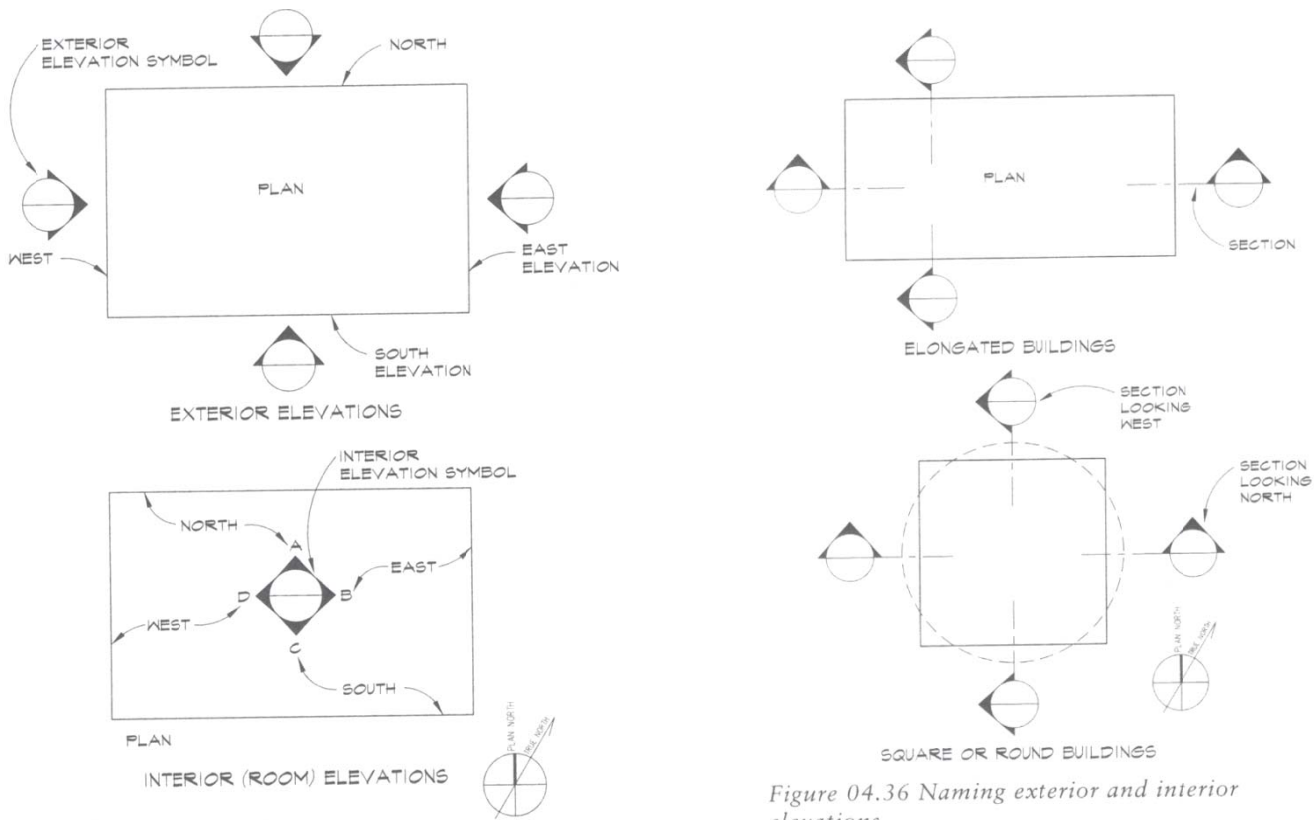

Figure 04.36 Naming exterior and interior elevations.

### D. BUILDING SECTIONS

The following list of items should be included in all building section drawings:

- Key plan showing building section cut lines.
- Scale. Indicate scale on all building sections.
- Column grid lines, if used, should be shown at top of each section.
- Match lines, if used.
- Other building section references that intersect the building section. The tail of the intersecting building section reference should point in the direction that the section is cut.
- Room numbers within the section.
- Floor-to-floor dimensions.
- Finish grade.
- Ceilings and partitions that are cut in section.
- Major materials, symbols, and abbreviations lists. Show only a minimum amount of material indications where changes or termination of materials occurs

### E. WALL SECTIONS

The following list of items should be included in wall section drawings:

- Interior and exterior materials and finishes.
- Detail references.
- Finish grade.
- Floor levels, floor-to-floor dimensions. Do not show ceiling heights documented in Finish Schedule or on the reflected ceiling plan, unless it is necessary for clarification.
- Profile of built-in equipment against wall.
- Louvers. Coordinate with Mechanical.
- Masonry coursing relative to the dimensions shown on the section.



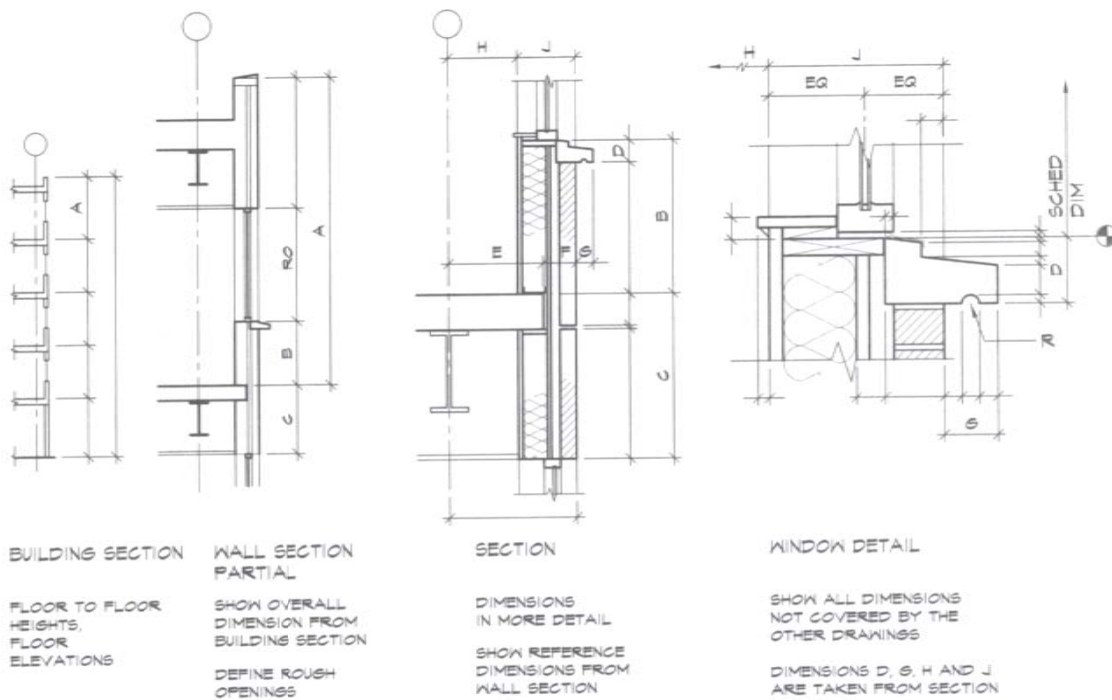

Figure 04.37 Hierarchy of dimensions.

## F. ENLARGED FLOOR PLANS

Place a dashed line around areas or rooms to be enlarged to provide more extensive detailing and dimensions. Stairwells, toilet rooms, kitchens, laboratories. Do not duplicate information on smaller scale plans.

### Toilet Rooms

Dimension the centerline of each plumbing fixture and tie all dimensions to a fixed point.

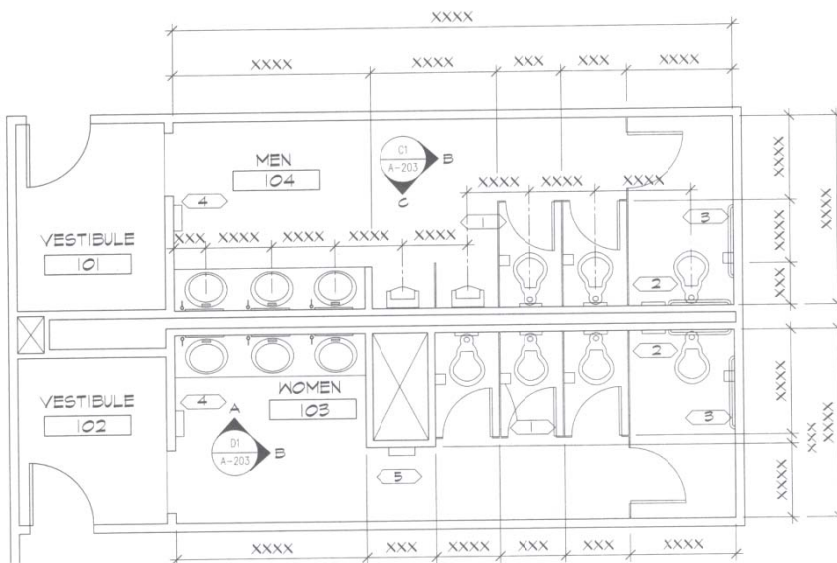

Figure 04.38 Example of a toilet plan showing dimensioning, accessory identification, and reference to elevation.

**G. STAIR SECTIONS**

Draw these sections adjacent to the plans associated with them. The first level plan should be placed at the bottom of the sheet with subsequent levels arranged vertically above in an orderly succession.

Stair sections should show the number of risers, headroom dimension, and details for handrails and guardrails. Caution should be paid to avoid over drafting.

The following list of items should be included in stair section drawings:

- Concrete stairs are detailed by Structural. Unless applied finishes are provided (i.e., terrazzo, granite, and special handrails), eliminate drawing these sections. Reference tread nosing, handrails, and other architectural features from floor plans or building sections.
- If fire hose or fire valve cabinets occur in stairs, show these in section and dimension heights and location.
- Tie dimensions to the number of risers and observe minimum clearances.
- Draw handrails and guardrails in detail.
- Draw a detail at slab edge and indicate whether the space below the first landing is enclosed by a furring partition.
- Indicate a ladder and roof hatch to access the roof. If roof access is through a stair penthouse, show a curb to raise the doorsill above the adjacent roof to facilitate flashing.

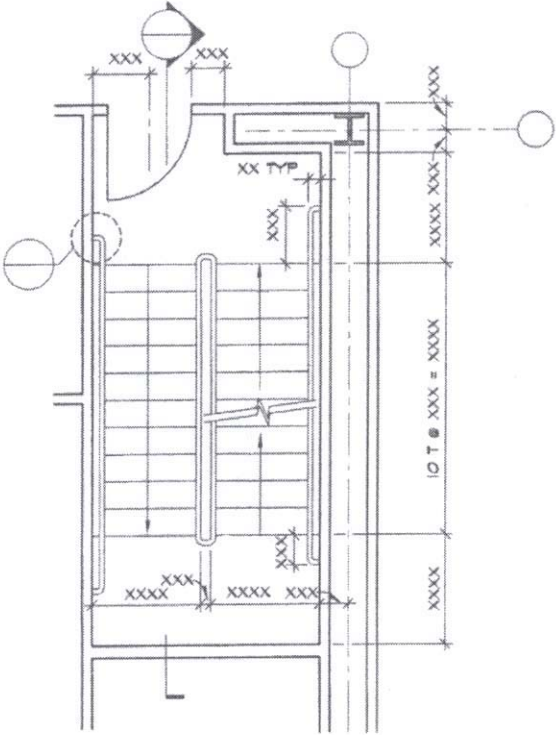
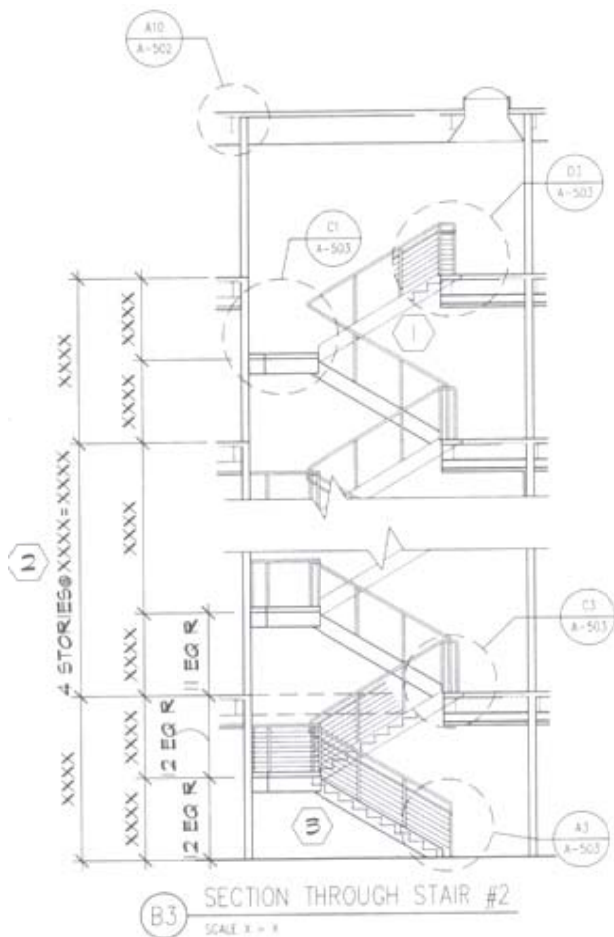
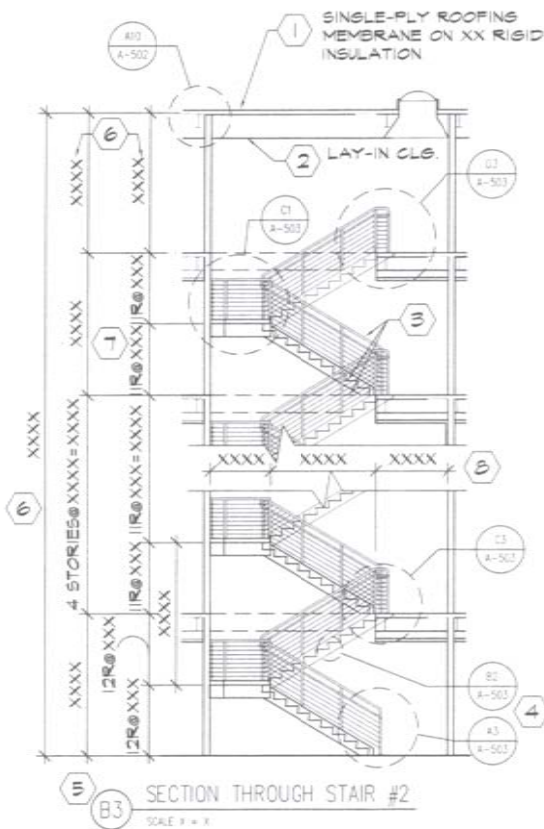

Figure 04.39 Stair plan.



- ① SHOW THE LEAST NUMBER OF STEPS (MANUAL DRAFTING).
- ② DO NOT SHOW REPETITIOUS IDENTICAL FLOORS ON MULTI-STORY PROJECTS, EVEN IF THERE IS SPACE TO INCLUDE THEM.
- ③ SHOW INTERMEDIATE RAILINGS AT THE TOP AND BOTTOM OF STAIR AND ANY ATYPICAL CONDITIONS ONLY (MANUAL DRAFTING).

Figure 04.40 Stair section



- ① INFORMATION OF INTEREST TO THE ROOFING SUBCONTRACTOR ONLY. ROOF PLAN AND DETAILS SUCH AS DETAIL A10/A-502 ALSO PROVIDE THIS INFORMATION.
- ② ROOM FINISH SCHEDULE AND REFLECTED CEILING PLAN DUPLICATE THIS INFORMATION.
- ③ REPETITIOUS AND TIME-CONSUMING DRAFTING THAT DOES NOT CONTRIBUTE ANY INFORMATION BEYOND THAT WHICH IS PROVIDED BY THE OVERALL DIMENSION.
- ④ THIS DETAIL SHOULD BE REFERENCED ON DETAIL C3/A-503.
- ⑤ REFERENCE SECTION TITLE TO FLOOR PLAN.
- ⑥ DIMENSION BELONGS ON BUILDING SECTION. STAIR FABRICATOR DOES NOT REFERENCE THIS INFORMATION.
- ⑦ REPETITIOUS INFORMATION AND DIFFICULT TO READ. USE THE ABBREVIATION "TYP" FOR REPETITIOUS DIMENSIONS.
- ⑧ THIS DIMENSION STRING IS DUPLICATED ON THE PLANS.





**V. CHECK LISTS**  
**FOR ARCHITECTURAL DRAFTING**



## V. DRAFTING CHECK LISTS FOR ARCHITECTURAL DESIGN

### USEFUL INFORMATION FOR ARCHITECTURAL DESIGN

*Further to our checking of several projects, we faced many repetitive mistakes, so please find hereafter a list of points to be taken into consideration in the architectural design and to which, each project should abide, where applicable:*

- Ramps:
  - Slope
  - Clearance
  - Curbstone
  - Screed
  - Radius
- Stairs:
  - Flight minimum width: 100 cm.
  - Landing minimum width: Equal to Flight Width.
  - Proportion between Risers Height & Treads Width should follow the rule of:  
 $60\text{cm} < 2R+T < 64\text{cm}$  (preferable value: 63cm)
  - Minimum Void between two flights: 20 cm
  - Balustrade
  - Clearance
  - Dry and Wet risers (if required) near staircase. Provide a recessed location where possible.
  - On 1/100, 1/50 scaled plans: Only upper limits should be drawn as hidden lines.
  - On detailed stairs plans: Beside the upper limits, concrete limits to be added as hidden lines and plaster limits as continuous lines.
- Lifts:
  - Machine room (Machine room above, machine room below, machine room less, hydraulic...)
  - Overhead Dimension
  - Hoist way: Minimum 160cm x 160cm.
  - Pit Dimension
  - Door opening system (Central, telescopic)
  - Minimum Door opening dimension: 80cm (Provide enough space for the doors when opened).
- Doors:
  - Reference (Wooden, steel, Aluminum...)
  - Dimensions (Bathrooms, technical rooms, entrance, other...)
  - Opening system (Casement, swinging, sliding, sectional, revolving)
  - Fire rating (Specs.)
  - Jambs
  - Clearance
  - Sub frame
  - Burglarproof protection doors



- Windows:
  - Reference (Wooden, steel, Aluminum...)
  - Shutters
  - Dimensions
  - Opening system (Casement, swinging, sliding, sectional, revolving)
  - Cleaning system
  - Sills
  - Jambs
  - Height from floor finishes level and top level
- Shutters:
  - Material (Wooden, steel, Aluminum...)
  - Maximum width ~270cm
  - Shutters on internal angle
  - Type (Casement, rolling, folding)
  - Fixation
- Gate:
  - Heights
  - Pedestrian access
  - Steel specs and dimensions
  - Type (Casement, Sliding, folding, ...)
- Corridor:
  - Width  $\geq$  110 cm
- Rooms:
  - Maid room dimensions
- Bathrooms:
  - Washbasin type (Free Standing, Recessed, Semi Recessed...)
  - W.C. (Floor type, Wall Hung)
  - Bidet (Floor type, Wall Hung)
  - Bathtub
  - Distance from axis to wall
  - Distance from axis to axis
  - Shower Tray
  - Shower enclosure
  - Tiling
- Balustrade:
  - Material
  - Height (Safety Code)
- Gutter (Concrete, Stone, Zinc,...)
- Planters:
  - Depth
  - Waterproofing
  - Drainage
- Waterproofing on terraces:
  - Accessible
  - Not accessible
  - Joints
- Water tank access (From top or from side)
- Water tank ladder (Stainless steel)
- Pump room:
  - Trench reference tag
  - Level
- Fuel tank room: Threshold as per legal requirements

- Generator room: (Air exhaust, fresh air and gas exhaust) as per safety requirements
- Boiler room: (Chimney, double pipe circuit, Air Exhaust & Fresh Air...)
- Chimneys height on roof level
- Shafts (Partition inside exhaust shaft): Access panel location
- Fire rated partitions between two ducts in a same shaft should be mentioned on the Mechanical Drawings and in the Architectural BOQ & Specs.
- Exhaust & Fresh air: Basements and on Elevations (Hood, AHU)
- Provide Riser & Outlets for Toilets in each shop in Commercial Area.
- Swimming Pool:
  - Dimensions
  - Shape (Slopes on section)
  - Overflow trench
  - Compensation Tank
- Schedules must be divided into Four main categories:
  - Schedule of Wooden Works: Doors (DW), Windows (WW), Closets ...
  - Schedule of Aluminum Works: Doors (DA), Windows (WA), Louvers ...
  - Schedule of Steel Works: Doors (DS), Windows (WS), Access traps, Balustrades, Fences, Louvers, Trenches
  - Schedule of Finishes
- Coordinate with EPQS department:
  - Cornice (Reference)
  - Molding (Reference)
  - Balustrade (Reference)
  - Hardware type
  - Signage file
- Coordination with Structural & Electro-Mechanical departments.
- All "**Title Block**" inserted onto the layout must have an Insertion Point with "0,0,0 coordinates"

- All "**Floor Plans Views**" of the same project must have on the layouts the same position. The best way to do so is to adjust one of the floor plan layouts, give it a label (else than *Layout1* or *Layout2* ex:1681T-A1) and then import it onto the other drawings.

To **Import Layout onto a drawing** do one of the following:

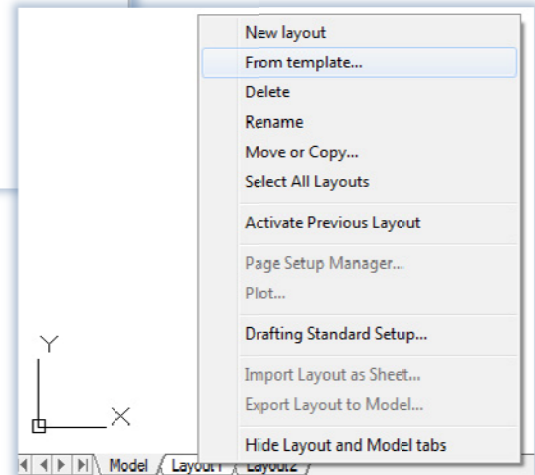
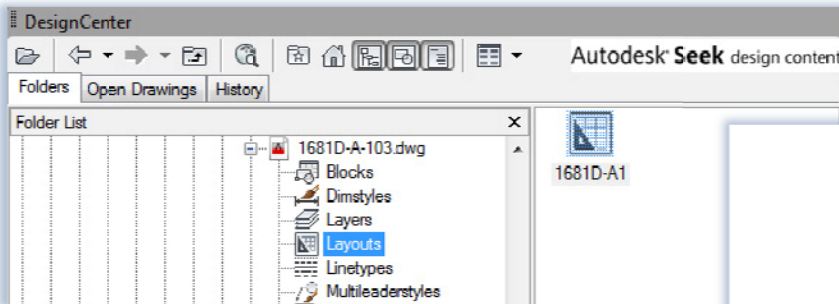

- Open the *Design Center (ADC* Shortcut), browse for the drawing where the layout is adjusted and labeled, select the layout and then drag it onto the drawing.
- Or Right Click on any of the Model or Layout Tabs then select "From Template", Browse for the file where the layout is adjusted and labeled, Select the proper Layout.

- Layers: (Erga Tool Palettes)
  - Major / Minor groups
  - Freeze in current view port for all unused XREF layers
  - Freeze / Off
- Avoid using wblocks, better use Xrefs – overlay not attachment
- Set the Snap base on 0,0,0 – Snap shall be:
  - 50 mm → All drawings
  - 1 mm → Detail
- Draw properly in order to have rounded Dimensions values:  
No override / No Round of...

- UCS: Use # UCS for each elev., sec., wall sec., details – All to be on 0,00 level to use point or line ID

- Enlarged views should be also on 0,0,0

- Leader: - Not lines and arrows  
- Annotation system



(text always "Left Justify")

- Tiling & False ceiling pattern (Never have < 1/2 tile)
- Distance reference between different drawings on a same file.

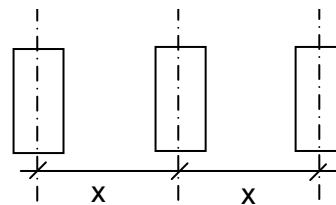

- To copy lines from Xref, use "Copy nested object" command:  
Go to Express / blocks/ Copy nested object.

- Always **Draw New Files** for development – **Never** use Conceptual files.

# DRAFTING PERMIT CHECKLIST



PREPARED BY:		PROJECT NO & ID:	DATE:
		SECTOR/SUB-SECTOR:	PHASE:
Check	Item	Remarks	
	<b><u>1. GENERAL:</u></b>		
	North direction		
	Property line, Expropriation, Alignment, set back, road axes + dimensions.		
	Lot levels at all corners + level at mid-road elevation.		
	Levels at all floors.		
	Refer & Adopt road levels from Beirut Municipality for all Beirut projects.		
	Section tags.		
	Grid & Grid dimensions.		
	Arab text.		
	Tiling only in bathrooms and toilets.		
	Refer to Construction Regulations		
	Indicate lift pit & its level		
	<b><u>2. SITUATION:</u></b>		
	Neighboring lots and roads numbers.		
	Building outline only with shade or hatch.		
	No axis, no set back.		
	<b><u>3. IMPLANTATION &amp; SANITARY:</u></b>		
	Differentiate between indoor outlines (white), balconies outline (magenta) & terraces outline (yellow). (3 layers).		
	Legal areas outlines and annotations on velum paper.		
	Sanitary drainage to main city sewer or to septic tank.		
	Implantation of septic tank not less than 2m from plot limits disregarding the set back		
	Draw plan & section for the septic tank.		
	<b><u>4. FOUNDATION:</u></b>		
	Draw footings for all columns, retaining walls and tie beam.		
	Draw general dimensions only.		

	<b><u>5. BASEMENTS</u></b>	
	To consider the 1st basement as a basement floor not an exploited floor, it should have at least 60% of it's elevations backfilled, its ceiling level should be at Max.1M above road's midlevel and its floor under the lower road level.	
	The parking clear height > 2.2m.	
	Length & percentage level for each ramp slope as per regulations.	
	The ramp entrance clear height > 2m.	
	Cars dimensions & spacing as per regulations.	
	Spaces annotations to refer to building functions.	
	Ramp width as per regulations.	
	Fresh Air & Exhaust fan for generator room, and door annotation.	
	<b><u>6. GROUND FLOOR:</u></b>	
	No construction is allowed within the road setback. (do not draw in setback).	
	Electrical transformer (According to Electrical Department Authority)	
	Allowable floor clear height is 4.5m without Mezzanines	
	Piloti clear height min=2.2m	
	<b><u>7. TECHNICAL FLOOR:</u></b>	
	Maximum clear height concrete to concrete is 1.8m. (no tiling)	
	<b><u>8. FLOORS:</u></b>	
	Draw rectangle 450cm x 550cm for legal open view range representation where critical.	
	In the road setback, no balconies are allowed under 3.5m.	
	Only general dimensions are requested.	
	Where flowerbed width >60cm, include its area in the balconies areas.	
	Exhaust fan Ø15 cm for each closed bathroom or toilet.	
	Legal open view range for maid rooms, if not change name to storage.	
	Where escape stairs are needed, include their area in the balconies area.	
	<b><u>9. PENTHOUSE:</u></b>	
	Where allowable, and where space allocation heights exceed 2.5m, add those spaces areas into indoor exploitation area.	

	<b>10. ROOF FLOOR:</b>	
	Draw staircase and machinery room. (not the lift drawing)	
	<b>11. SECTIONS:</b>	
	Floor annotations.	
	Vertical dimension of each floor	
	Level of each floor	
	Road and neighbor levels.	
	Natural land profile	
	Retaining wall height for land grading <3.5m from Natural Soil Level.	
	Fence height <2m concrete + 1m open fence.	
	Penthouses min slope is 25° and maximum height is 3m to top of concrete.	
	Draw outline "Gabarit" from roads & neighbours with dimensions and annotations.	
	<b>12. ELEVATIONS:</b>	
	Natural Land profile	
	Retaining wall height for land grading <3.5m.	
	Fence height ≤2m concrete + 1m open fence (Neighbour Side) ≤1.2m concrete + 1m open fence (Road Side)	
	Penthouses min slope is 25° and maximum height is 2.5m to top of concrete.	





# DRAFTING PRELIMINARY CHECKLIST



PREPARED BY:		PROJECT NO & ID: SECTOR/SUB-SECTOR:	DATE: PHASE:
Check	Item	Remarks	
	<b><u>GENERAL:</u></b>		
	Drawing title (Date, number...) Erga logo, scale		
	Grid & Main Axis		
	North sign		
	Section tags		
	Layers, Line thickness, pen assignment		
	Property line, Expropriation, Alignment, Set back, Road axis, + Dimensions		
	Refer to Construction Regulations		
	<b><u>Plans</u></b>		
	Greyscale or colored shades for walls		
	Tiles, furniture, plants, vehicles		
	Trees, grass, landscaping blocs for external rendering.		
	Multigrade level shades for roads and circulation		
	Use of coloured images and pens colours for coloured printout.		
	True type bold text (ex: Arial Black)		
	<b><u>Elevations-Sections</u></b>		
	External materials hatch or image		
	Greyscale shades for shadows		
	Trees, people, vehicles' etc... for rendering		



# DRAFTING CONSTRUCTION CHECKLIST



PREPARED BY:		PROJECT NO & ID: SECTOR/SUB-SECTOR:	DATE: PHASE:
Check	Item	Remarks	
	<b><u>Construction Document Phase (Design Development)</u></b>		
	This List is to guide the architect to better produce complete drawings, and to assist him in the checking procedure of all drawings. It is divided by floors, elevations and sections, Wall Sections, Details and Schedules. (Only Floors are listed)		
	<b><u>GENERAL:</u></b>		
	Use snap ( 50mm for plans, section...&1mm for details)		
	Check useful layers ON, unused layers OFF		
	Implantation of layout drawings is correct (0,0,0)		
	Scales noted and checked		
	Model space / paper space views are correct		
	Dimensions correct, check dimscale & dimlfac		
	Grid location, dimensions, grid ID style and height the same in all drawings		
	Room references noted & checked		
	Shaft & opening locations and dimensions coordinated with other discipline		
	Doors, windows, louvers... references noted & checked		
	Layers are used correctly as Erga standards		
	Columns, Beams & Walls coordinated with other discipline		
	Details references noted & checked		
	Hatches are used correctly as Erga standards		
	Levels for all floors and pitched roof are noted correctly		
	Finishing references noted & checked		
	Sections reference details correctly labeled and oriented		
	Symbols correct (levels, sections...)		
	`Slopes in slabs noted		
	North Sign (only on plans) exists and correct		
	Linetype scale correct (Ltyscale)		
	Title block: Drawing title (Date, numbers...) key plan & key section		
	Erga logo is correctly filled		
	Prepare plan notes		
	Purge unused layers		

	Update list of drawing	
	General notes & abbreviations updated for each project	
	Notes to be specifics to each project	
	Fire rate	
	Stairs & lift dimensions	
	Corridors > 110cm	
	<b><u>BASEMENT:</u></b>	
	Lift pit in last basement level.	
	No lift drawing in lift pit.	
	Chamfer water tank corners plan and section with projection to chamfer.	
	Circulation sign + Road sign in section + Car parking limits + Car Stop (In floor finishing plan)	
	Drop Beams Projection and Coordinate with Other Discipline	
	Waterproofing with its protection system for all basement walls	
	<b><u>GROUND FLOOR &amp; PILOTIS:</u></b>	
	Fencing.	
	Access levels/ Road levels	
	Drop Beams Projection and Coordinate with Other Discipline	
	<b><u>TYPICAL FLOOR:</u></b>	
	All fire hose cabinets must be in 25cm block walls at least.	
	Before any development, ensure the knowledge of architectural and technical requirements and place complete list with detail sketches and catalogues.	
	Drop Beams Projection and Coordinate with Other Discipline	
	<b><u>PENTHOUSE AND ROOF:</u></b>	
	Waterproofing & Insulation with their protection system	
	Drop Beams Projection and Coordinate with Other Discipline	